

Module 1

Introduction, Solar Radiation Measurement of Solar Radiation

Introduction

The word 'energy' itself is derived from the **Greek** word 'en-ergon', which means 'in-work' or work content. The work output depends on the energy input. Energy is the most basic infra-structure input required for economic growth & development of a country. Thus, with an increase in the living standard of human beings, the energy consumption also accelerated.

A systemic study of various forms of energy & energy transformations is called energy science. While fossil fuels will be the main fuel for thermal power, there is a fear that they will get exhausted eventually in the next century. Therefore other systems based on non- conventional & renewable sources are being tried by many countries. These are solid, wind, sea, geothermal & bio-mass.

Classification of Energy Sources

Energy can be classified into several types based on the following criteria

Based on usability of Energy – Primary and Secondary sources

- Primary resources - are those that are embodied in nature, common primary energy sources are coal, oil, natural gas, sunlight, wind and biomass (such as wood). Other primary energy includes nuclear energy from radioactive substances like uranium etc. these resources generally available in raw form. These resources are extracted, processed and converted to a form required by the consumer.
- Secondary resources – are supplied directly to consumer for utilization after one or more steps of transformation e.g., electrical energy and thermal energy.

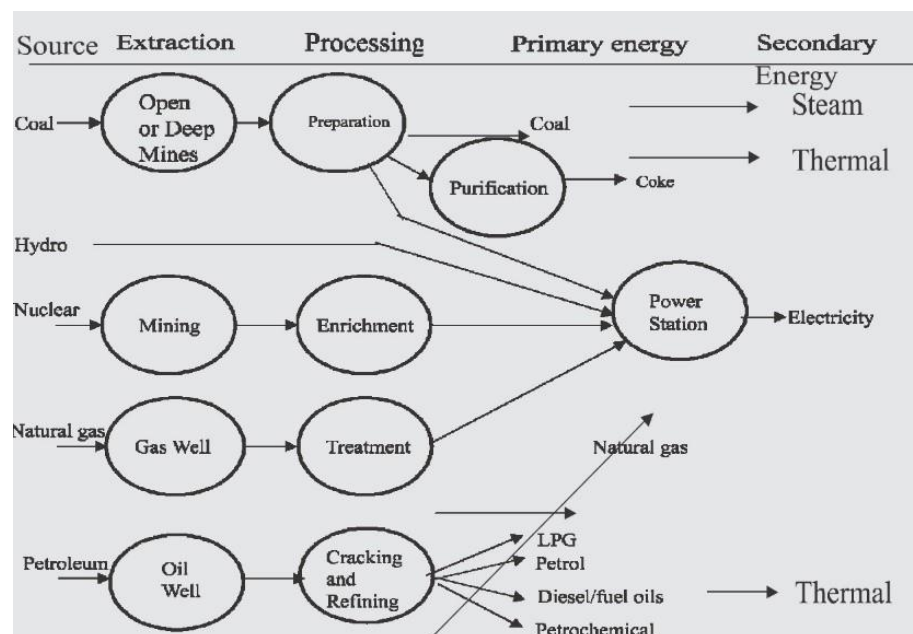

Based on Long-term Availability – Renewable and Non-renewable

- **Renewable sources** – which are obtained from sources that are essentially inexhaustible. Examples wind, solar, tidal and geo-thermal etc.,
- **Non-renewable sources** – which are finite do not get replenished after their consumption or these sources are exhaustible do not quickly replenished. Examples fossil fuels, nuclear etc.,

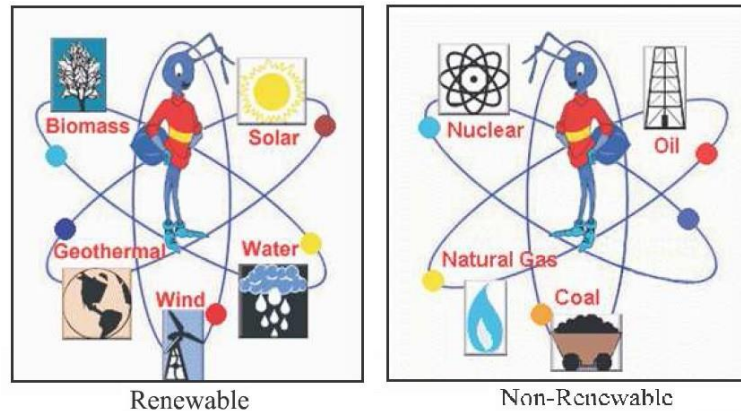

Based on traditional use – Conventional and Non-conventional

- **Conventional** – energy resources which are being traditionally used for many decades and were common in use around oil crisis of 1973. E.g., fossil fuels, nuclear and hydro-resources.

Non-conventional – energy resources which are considered for large scale use after the oil crisis of 1973. E.g., solar, wind, biomass etc.

Based on commercial Application

- **Commercial Energy resource** - energy sources that are available in the market for a definite price. In the industrialized countries, commercialized fuels are predominant source not only for economic production, but also for many household tasks of general population. Examples electricity, coal and refined petroleum products.
- **Non-Commercial Energy** - energy sources that are not available in the commercial market for a price. which are traditionally gathered, and not bought at a price used especially in rural households.

Examples Firewood, agricultural waste in rural areas; solar energy for water heating, electricity generation, for drying grain, animal power for transport, wind energy for lifting water and electricity generation.

India's production & reserves of commercial sources

- Fossil fuels – i.e., solid fuel coal including anthracite, bituminous, peat and lignite, liquid fuels including petroleum and its derivatives and natural gas.
- Hydro-power
- Energy of nuclear fission
- Minor sources of energy include sun, wind, tides, geo-thermal etc.,
- Coal and Lignite

Coal is highly carbonaceous material formed when dead plant submerged in swamp environments is subjected to the geological forces of heat and pressure over hundreds of millions of years.

- Coal - has been considered as the major source of energy in India. It can be easily converted into other forms of energy such as electricity, gas and oil.
- The total estimate resources of coal are now placed at 1, 48, 79 million tonnes, but the mineable reserves are estimated to be 80,000 million tonnes i.e., on 55% of the total coal reserves.
- Lignite is brown coal with lesser amount of energy. In 1950-51, production of coal and lignite in India was 32.3 million tonnes which increased to 413 million tonnes in 2004-05.

Oil and Natural Gas

Demand for fossil fuels grew rapidly with the growth of the industrial sector and transport services. After Independence, the Government of India felt the need for oil exploration on an extensive scale, and therefore, (ONGC) was set up in 1956, and (OIL) was established in the year 1959.

- Total recoverable reserves of oil are estimated at 550 million tonnes and those of gas are estimated at 500 billion cubic tonnes.
- Production of crude oil is estimated in 2004- 05 at about 54 million tonnes and only 10 % of the total potential has been utilized.

Hydroelectric power

It plays an important role in the field of power development in India, our country has made considerable progress in the field of hydroelectricity power generation.

- It is the most economical source of power
- There no environmental pollution problem
- There is no waste disposal problem
- The annual hydroelectric potential is estimated to be around 90,000 MW (Mega-watt). Out of this, so far about 18,000 MW has been developed. This mean that only 20% of the total potential has been utilized.

Atomic or Nuclear Power

India has also developed nuclear power. Uranium and thorium are both sources of nuclear power generation. India's uranium reserves have been estimated to be of the order of about 70,000 tonnes, which is equal to 120 billion tonnes of coal.

Similarly, our thorium reserves of 3, 60,000 tonnes would be equivalent to 600 billion tonnes of coal.

- Considering the availability of uranium and thorium, the government of India took

steps in setting up nuclear power plants at Tarapur (Maharashtra) , Kalpakkam (Tamil Nadu) during 1984- 86, Narora (Uttar Pradesh) during 1989-91 and only 3% of the total potential has been utilized.

Non-commercial energy sources

- Fuelwood – used for cooking purpose its estimated about 223 million tonnes in 2020-21.
- Agricultural waste -It is also used how for cooing purpose its estimated about 65 million tonnes in 2001.
- Animal dung commonly used as fuel in our rural India, out of the total estimated production of 324 million tonnes of animal dung, nearly 73 million tonnes and only 10% of the total potential is burnt as fuel every year.

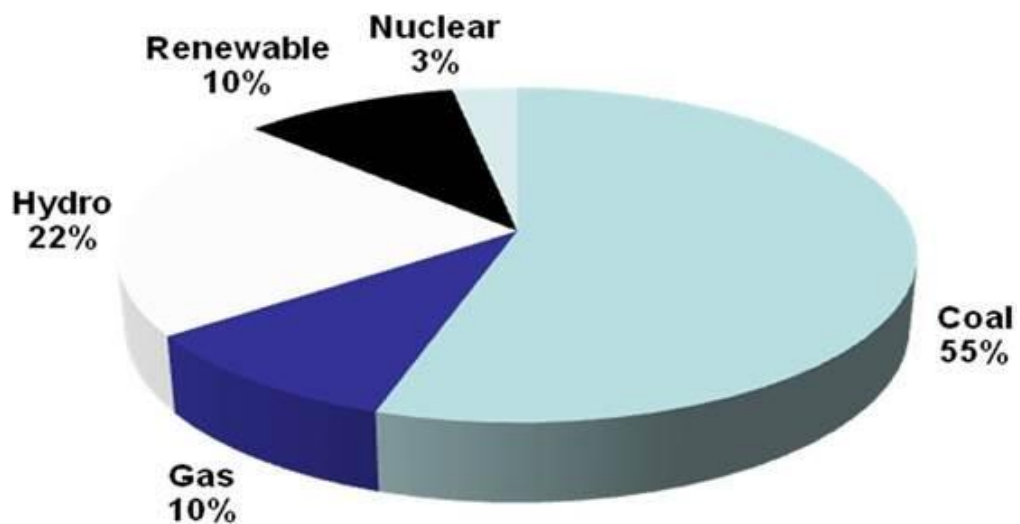

Importance of Non-commercial energy resources:

The concern for environmental due to the ever increasing use of fossil fuels & rapid depletion of these resources has led to the development of alternative sources of energy, which are renewable & environmental friendly. Following points may be mentioned in this connection.

- 1) The demand of energy is increasing by leaps & bounds due to rapid industrialization & population growth, the conventional sources of energy will not be sufficient to meet the growing demand.
- 2) Conventional sources (fossil fuels, nuclear) also cause pollution; there by their use degrade the environment.
- 3) Conventional sources (except hydro) are non-renewable & bound to finish one day.
- 4) Large hydro-resources affect wild-life, cause deforestation & pose various social problems, due to construction of big dams.
- 5) Fossil fuels are also used as raw materials in the chemical industry (for chemicals, medicines, etc) & need to be conserved for future generations.

Due to these reasons it has become important to explore & develop non-

conventional energy resources to reduce too much dependence on conventional resources. However, the present trend development of NCES indicates that these will serve as supplements rather than substitute for conventional sources for some more time to time.

SALIENT FEATURES OF NON-CONVENTIONAL ENERGY RESOURCES

Advantages

- NCES are available in nature, free of cost.
- They cause no or very little pollution. Thus, by and large, they are environmental friendly.
- They are inexhaustible.
- They have low gestation period.

Disadvantages

- Though available freely in nature, the cost of harnessing energy from NCES is high, as in general, these are available in dilute forms of energy.
- Uncertainty of availability: the energy flow depends on various natural phenomena beyond human control.
- Difficulty in transporting this form of energy.

SALIENT FEATURES OF CONVENTIONAL ENERGY RESOURCES

ADVANTAGES

- Coal: as present is cheap.
- Security: by storing certain quantity, the energy availability can be secured for a certain period.
- Convenience: it is very convenient to use.

DISADVANTAGES

- 1) Fossil fuels generate pollutants: CO, CO₂, NO_x, SO_x. Particulate matter & heat. The pollutants degrade the environment, pose health hazards & cause various other problems.
 - 2) Coal: it is also valuable petro-chemical & used as source of raw material for chemical, pharmaceuticals & paints, industries, etc. From long term point of view, it is desirable to conserve coal for future needs.
 - 3) Safety of nuclear plants: it is a controversial subject.
 - 4) Hydro electrical plants are cleanest but large hydro reservoirs cause the following problems
 - 5) As large land area submerges into water, which leads to deforestation.
 - 6) Causes ecological disturbances such as earthquakes
 - 7) Causes dislocation of large population & consequently their rehabilitation problems.
-

SOLAR ENERGY:

- Solar energy is a very large, inexhaustible source of energy. The power from the Sun intercepted by the earth is approximately 1.8×10^{11} MW which is many thousands of times larger than the present consumption rate on the earth of all commercial energy sources. Thus, in principle solar energy could supply all the present & future energy needs of the world on a continuing basis. This makes it one of the most promising of the unconventional energy sources.
- Solar energy is received in the form of radiation, can be converted directly or indirectly into other forms of energy, such as heat & electricity. This energy is radiated by the Sun as electromagnetic waves of which 99% have wave lengths in the range of 0.2 to 4 micro meters.
- Solar energy reaching the top of the Earth's atmosphere consists about 8% U.V radiation, 46% of visible light, 46% Infrared radiation.

Classification of methods for solar energy utilization:

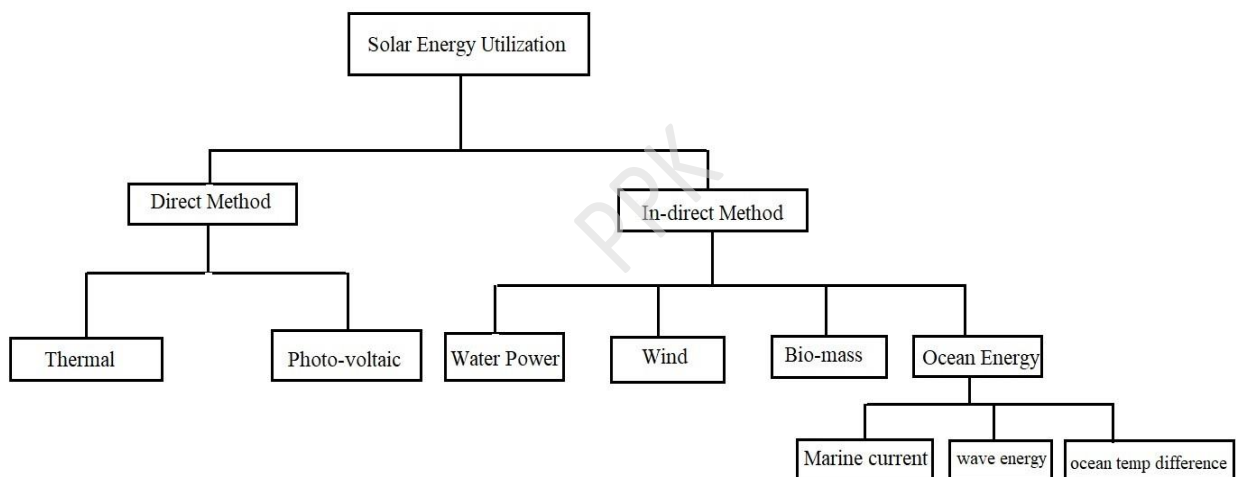

Merits of solar energy:

- It is an environmental clean source of energy
- It is free & available in adequate quantities in all most all parts of world where people live.

Demerits of solar energy:

- It is a dilute source of energy because even in hottest region the radiation flux is available only 1 KW/m^2 & total radiation over a day is 7 KW/m^2 .
- These are low values from the point of view of technological utilization.
- It is required large collecting areas are required in many applications & these results increase of cost.
- Solar energy availability varies widely with time, it occurs because of the day-night cycle & also seasonally because of the Earth's orbit around the Sun [even local weather condition.

Solar applications

- ✓ Solar heating
 - ✓ Solar cooling
 - ✓ Solar pumping
 - ✓ Solar furnace
-

- ✓ Solar production of hydrogen
- ✓ Solar green houses
- ✓ Solar distillation
- ✓ Solar energy
- ✓ Solar cooking

Thermal Energy:

Thermal energy refers to the internal energy present in a system in a state of thermodynamic equilibrium by virtue of its temperature. The average translational kinetic energy possessed by free particles in a system of free particles in thermodynamic equilibrium. This energy comes from the temperature of matter.

Thermal energy is the total energy of all the molecules in an object.

The thermal energy of an object depends on the 3 things:

1. The number of the molecules in the object
2. The temperature of the object (average molecular motion)
3. The arrangement of the object molecules (states of matter)

There are 3 modes of thermal energy

1. Conduction,
2. Convection,
3. Radiation

1. **Conduction:** Heat is transferred from one molecule to another without the movement of matter.

2. **Convection:** Fluids (liquids & gases) transfer heat by convection, a process that causes mixing of the warmer regions with the cooler regions of liquid or gas.

The main difference between convection & conduction is that convection involves the movement of matter & conduction does not.

3. **Radiation:** it is the transfer of energy by electromagnetic waves.

Liquid flat plate collector

- In operation cold water from the overhead tank is made to flow through water tubes.
- When solar radiation passes through transparent glass cover & falls on the absorber plate it absorbs heat energy.
- This heat energy transferred to the cold water flowing through the tube and gets heated up.
- Heated water being lighter in density than cold water hence it raises up and collects in the solar water heater tank.

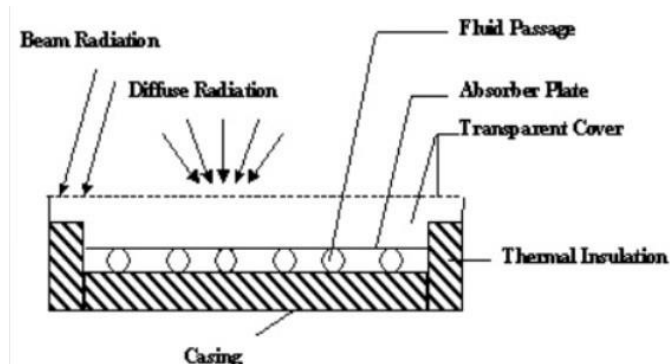

ADVANTAGES:

- It is eco friendly
- Renewable sources
- No/less pollution
- By using this produce electricity
- Its help full for oil refining in Industry & home heating

DISADVANTAGES:

- Producing greenhouse gas
- Collecting of energy is a big problem, it requires sophisticated technology hence cost is more.

Applications:

- Steam engine
- Gasoline engine

Photovoltaic (PV) or Solar Cell:

Photovoltaic (PV) or Solar Cell

It is a device that converts solar energy into electric current using the photoelectric effect.

Photovoltaic power generation employs solar panels, composed of number of solar cells containing photovoltaic material. Photovoltaics are made up of semiconductors & it converts solar radiation into direct current electricity.

Working Principle

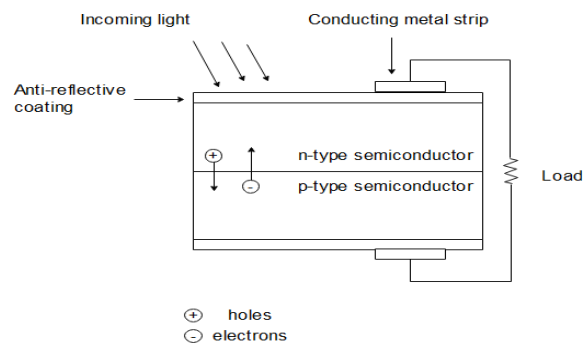

- photo-voltaic cell is made up of semi-conductor materials like silicon one layer has n-type silicon and another layer has P-type silicon and interface between n-type and p-type silicon is called P-n junction.
- In a P-n junction semi-conductor material, electrons from n-side tend to move towards P-side rapidly combine with large number of holes concentration.
- Similarly holes from P-side tend to move towards n-side rapidly combine with large number of electron concentration, this charge distribution across the junction gives rise to electrical field.
- When a P-n junction semi-conductor material exposed to the sunlight some of the solar photons will have a tendency to dislodge free-electrons from its fixed position in the material.
- Ejected free-electrons tend to move towards p-side and this flow negatively charged electrons

constitute an electric current.

Advantages

- Very little research money has been invested in the development of solar cells.
- It gives long duration period.
- Operating costs are extremely low compared to existing power technologies

Applications

- These solar cells are used to operate irrigation pumps
- Navigational signals, rail road crossing.
- To operate calculator & watches.

WATER POWER (HYDRO POWER):

Power derived from the energy of falling water & running water, which may be harnessed for useful purposes. In ancient years hydro- power has been used for irrigation & the operation of various mechanical devices such as water mills, saw mills, textile mills, domestic lifts, power house & paint making.

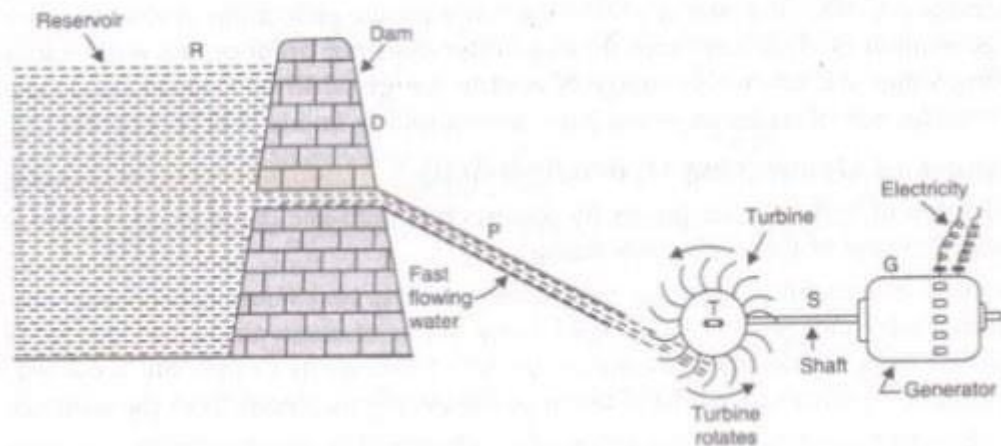

Classification of hydro power

- ✓ Conventional hydroelectric, referring hydroelectric dams
- ✓ Run of the river hydroelectricity, which captures the kinetic energy in rivers or streams without use of dams.
- ✓ Small hydro projects are 10 MW or less & often have no artificial reservoirs.
- ✓ Micro hydro projects a few KW to a few hundred KW isolated homes, villages or small industries.

The power available from falling water can be calculated from the flow rate & density of water, the height of fall & the local acceleration due to gravity.

$$P = \eta * \rho * Q * g * h$$

Where, P – Power in Watts

η - dimension less efficiency of the turbine

ρ –density of water in Kg/m^3

Q- Flow in m^3/sec

g- Acceleration due to gravity

h- Height difference between inlet & outlet

WIND ENERGY

Energy of wind can be economically used for the generation of electricity.

Winds are caused from 2 main factors:

1. Heating & cooling of the atmosphere which generates convection currents. Heating is caused by the absorption of solar energy on the Earth's surface & in the atmosphere.
 2. The rotation of the Earth with respect to atmosphere & its motion around the sun
- The energy available in the wind over the Earth's surface is estimated to be 1.6×10^7 MW
 - Wind energy which is an indirect source of solar energy conversion can be utilized to run wind mill, which in turn drives a generator to produce electricity.
 - The combination of wind turbine & generator is sometimes referred as an *AERO-GENERATOR*.

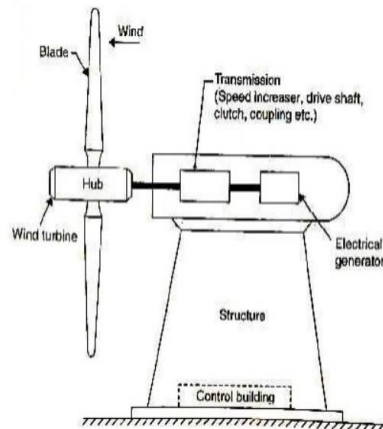

Figure: Wind-Electric generating power plant

- A step up transmission is usually required to match the relatively slow speed of the wind rotor to the higher speed of an electric generator.
- Data quoted by some scientists that for India wind speed value lies between 5 Km/hr to 15-20 Km/hr
- Wind farms are operating successfully & have already fed over 150 lakh units of electricity to the respective state grids.

The power in wind

Wind possesses energy by virtue of its motion. There are 3 factors determine the output from a wind energy converter,

- The wind speed,
- The cross section of wind swept by rotor &
- The overall conversion efficiency of the rotor, transmission system & generator

or pump.

- Only 1/3rd amount of air is decelerating by the rotors & 60% of the available energy in wind into mechanical energy.
- Well-designed blades will typically extract 70% of the theoretical max, but losses incurred in the gear box, transmission system & generator or pump could decrease overall wind turbine efficiency to 35% or less.
- The power in the wind can be computed by using the concept of kinetics. The wind mill works on the principle of converting kinetic energy of the wind to mechanical energy.

$$\text{Kinetic energy} = k.E = \frac{1}{2}mv^2$$

$$\text{But } m = \rho Av$$

$$\text{Available wind Power} = P_a = \frac{1}{8} \rho \pi D^2 V^3 \dots \dots \dots \text{Watts}$$

Power coefficient

The fraction of the free flow wind power that can be extracted by a rotor is called the power coefficient.

$$\text{Power coefficient} = \frac{\text{power o wind rotor}}{\text{pow available wwn the wind}}$$

The max theoretical power coefficient is equal to 16/27 or 0.593.

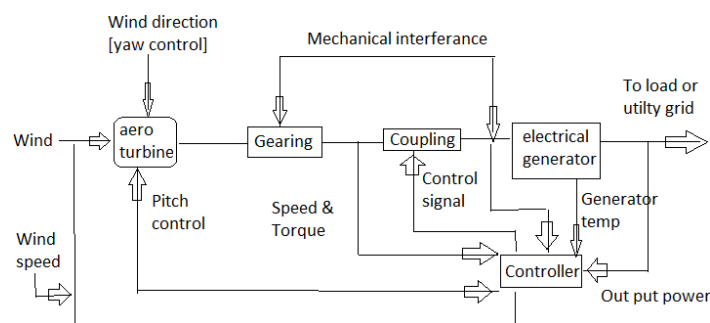

Fig Basic components of wind electric system

Biomass

- Bio-mass means organic matter.
- The energy obtained from organic matter, derived from biological organisms (plants & animals) is known as bio-mass energy.
- The average efficiency of photosynthesis conversion of solar energy into bio mass energy is estimated to be 0.5% - 1.0%.
- To use biomass energy, the initial biomass maybe transformed by chemical or biological processes to produce intermediate bio-fuels such as methane, producer gas, ethanol & charcoal etc.
- The pollutant emissions from combustion of biomass are usually lower than fossil fuels.

- In simplest form the reaction is the process of photosynthesis in the presence of solar radiation, can be represented as follows
- In the reaction, water & carbon dioxide are converted into organic material i.e., CH₂O, which is the basic molecule of forming carbohydrate stable at low temperature, it breaks at high temperature, releasing an amount of heat equal to 112,000 Kcal/mole (469 KJ/mole).



The biomass energy is used directly by burning or is further processed to produce more convenient liquid & gaseous fuels

Bio-mass resources fall into three categories

1. Bio-mass in its traditional form solid bio-fuel - The first category is to burn the bio-mass directly & get the energy. (wood & agricultural residue), &
2. Bio-mass in non-traditional form liquid bio-fuel - In the second category, is converted into ethanol & methanol to be used as liquid fuels in engines.
3. Bio-mass in the 3rd category is gaseous bio-fuel called bio- gas (bio-gas contains 55to 65% Methane, 30-40% CO₂ & rest impurities i.e., H₂, H₂S, & some N₂).

Bio-mass resources include the following

1. Concentrated waste- - municipal solids, sewage wood products, industrial waste and manure of large lots.
2. Dispersed waste residue—crop residue, logging residue, disposed manure.
3. Harvested bio-mass, standby bio-mass, bio-mass energy plantation.

ADVANTAGES

- It is renewable source.
 - The energy storage is an in-built feature of it.
 - It is an indigenous source requiring little or no foreign exchange.
 - The forestry & agricultural industries that supply feed stocks also provide substantial economic development opportunities in rural areas.
-

- The pollutant emissions from combustion of biomass are usually lower than fossil fuels.

DISADVANTAGES

- It is dispersed & land intensive source.
- Low energy density
- Labour intensive & the cost of collecting large quantities for commercial applications are significant.

TIDAL ENERGY

- The tides in the sea are the result of the universal gravitational effect of heavenly bodies like SUN & MOON on the Earth. Periodic rise & fall of the water level of sea is called TIDE. These tides can be used to produce electrical power which is known as tidal power.
- When the water is above the mean sea level called flood tide.
- When the water is below the mean sea level called ebb tide.

Basic principle of tidal power

- To harness the tides, a dam built, across the mouth of the bay. It will have large gate in it and also low head reversible turbine.
- The difference in water level is obtained between the basin and sea.
- The constructed basin is filled during high tide and emptied during low- tide passing through sluices gate respectively.
- By using reversible water turbine, which can run continuously, both during high tide and low tide, turbine is coupled to generator.
- Potential energy of the water stored in the basin as well as energy during high tide, is used to drive the turbine which is coupled to the generator to generate electricity.

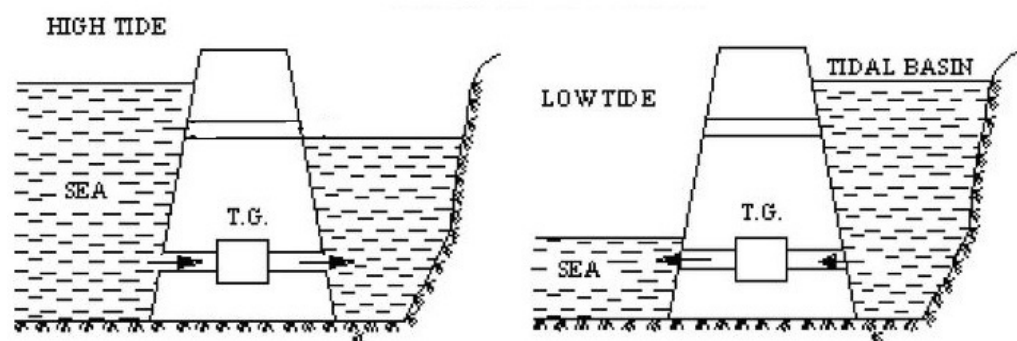

- Above arrangement of harnessing tidal energy called single basin plant. The plant continues generate power till the tide reaches, its lower level.
- The potential in ocean tides resource is estimated as 550 billion KWh/year [120,000 MW] power.

WAVES ENERGY

Waves are caused by the transfer of energy from surface of winds to sea. The rate of energy transfer depends upon the wind speed & the distance over which interacts with water.

- Wave Energy refers to the energy of ocean surface waves and the capture of that energy to do useful work - including electricity generation, desalination, and the pumping of water (into reservoirs).
- Wave power is a form of renewable energy.
- The energy flux in waves is more than that available from solar, wind & other renewable sources.
- Wave motion is highest at the surface and diminishes exponentially with depth; however, wave energy is also present as pressure waves in deeper water.
- Wave height is determined by
 - ✓ wind speed
 - ✓ the duration of time the wind has been blowing, fetch (the distance over which the wind excites the waves)
 - ✓ Depth and topography of the seafloor (which can focus or disperse the energy of the waves).

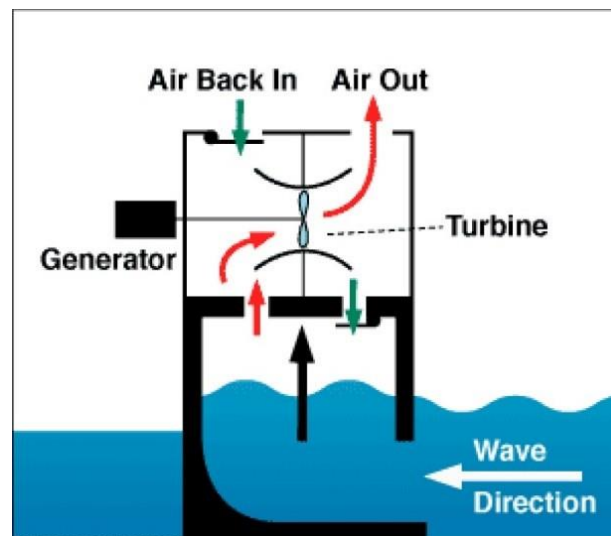

- It consists of two chambers and turbines, with a one chamber over the other.
- In operation when water go into low chamber, then the water in low chamber rises up and push up the air in the surface of water to turn a turbine.
- When the water drop down, so the air flow back into the space the chambers to turn turbine. Therefore, we can generate electricity from two turbines which make we have more profitable than only a turbine.

ADVANTAGES:

- The availability of large energy fluxes
- Productivity of wave conditions over periods of days.

DIS ADVANTAGES

- Irregularity of wave patterns in amplitude, phase & direction, which makes it difficult to extract power efficiently.

- The slow & irregular motion of wave is required to be coupled to be electrical generator requiring high & constant speed motion.
- The power extraction system is exposed to occasional extreme stormy conditions.

Geo-thermal Energy – is the energy which lies embedded within the earth crust. In other words heat energy stored deep inside the earth-crust. Volcanoes, Geysers, Hot springs & boiling mud pots are visible evidence of the great reservoirs of heat that lies within the earth.

- Most Geothermal energy produces low grade heat at about 50-70°c which can be used directly for thermal applications.
- Occasionally, geothermal heat is available at temperature about 90°c & so electrical power production from turbines can be contemplated.

Two ways of electrical power production from geothermal

1. Heat energy is transformed to a working fluid which operates the power cycle. This may be particularly useful at a place of fresh volcanic activity.

Where the molten interior mass of earth vents to the surface through fissures & substantially at high temperature, such as between 450 to 550 °c can be found. By embedding coil of pipes & sending water through them can be raised.

2. Hot geothermal water & or steam is used to operate the turbines directly. From the well head of the steam is transmitted by pipe lines up to 1 m in dia over distance up to about 3 Km to the power station. Water separators are usually required to separate the moisture & solid particles from steam.

Geothermal Power Plants

At a geothermal power plant, wells are drilled 1 or 2 miles deep into the Earth to pump steam or hot water to the surface.

- Hot water is pumped from deep underground through a well under high pressure.
- When the water reaches the surface, the pressure is dropped, which causes the water to turn into steam.
- The steam spins a turbine, which is connected to a generator that produces electricity.
- The steam cools off in a cooling tower and condenses back to water.
- The cooled water is pumped back into the Earth to begin the process again.

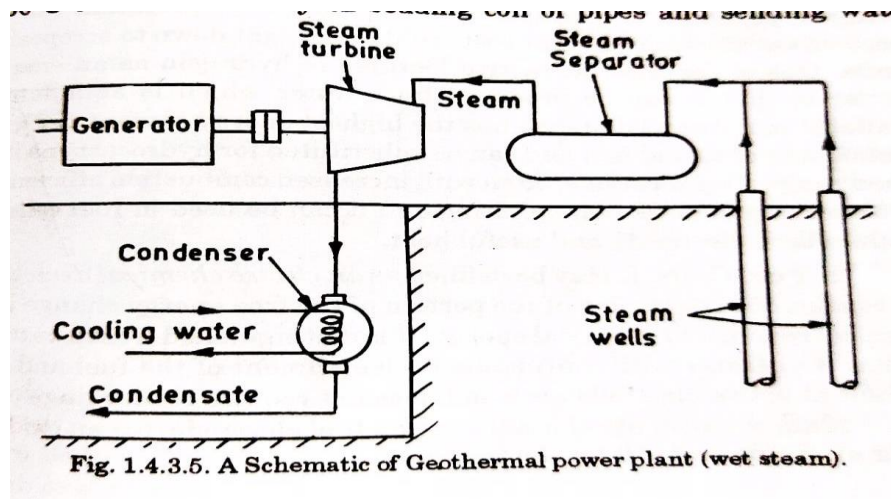

ADVANTAGES:

- It is reliable source of energy
- It is available 24 hours/day
- It is available is independent of weather
- It has an inherent storage future, so no extra storage facility is required
- Geo thermal plants require little land area.

DISADVANTAGES:

- Generally, energy is available as low-grade heat
- Continuous extraction of heated ground water may lead to subsidence [setting or slumping of land]
- Drilling operation leads to noise pollution
- Thermal energy cannot be distributed easily over long distances [longer than ~30 Km]
- Corrosive & abrasive geo thermal fluid reduces the life of plants.

Applications

- Direct heat use
- Electric power generation

TAR SANDS:

- Tar sand or oil sands is an expression used to describe porous sandstone deposits impregnated with heavy viscous oils called *bitumen or simply deposits of heavy oils*.
- The above schematic diagram indicating the processes involved in producing synthetic crude oil from tar sands made up of sand stone deposits containing bitumen.
- The sands obtained from surface mining are first passed through a conditioning drum where water, steam & *caustic soda* are added & *slurry* is formed. The slurry passes into a separation tank where the coarse sand settles at the bottom & a froth of bitumen, water & fine mineral matter forms on the top.

- The froth is diluted with *naphtha* & subjected to *centrifugal action*. As a result, fine mineral matter & water is removed. After this, the *naphtha* is recovered & recycled, & the bitumen obtained is subjected to hydro processing & desulphurization to produce synthetic crude oil.

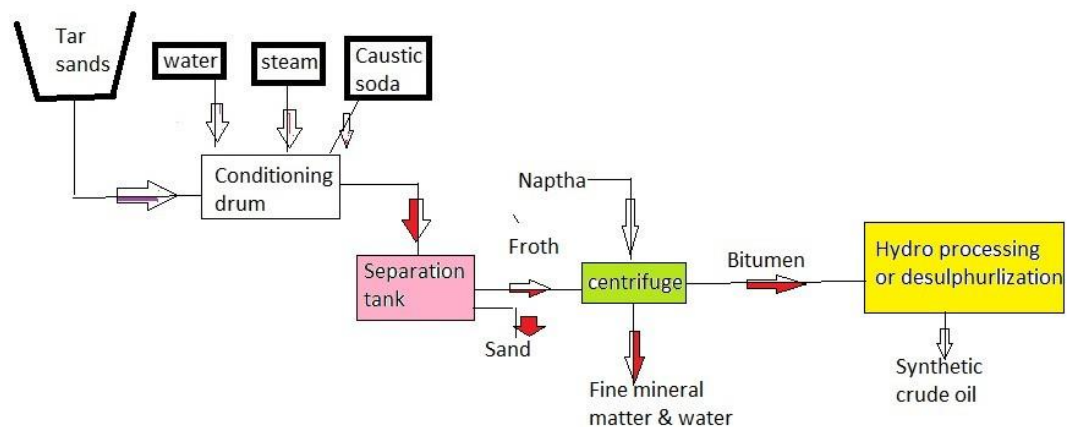

OIL SHALE:

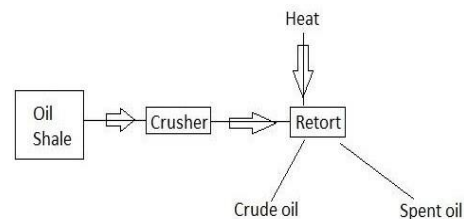

Fig Oil shale

Production of crude oil from oil shale

Oil shale [a sedimentary rock] refers to a finely textured rock mixed with a *solid organic material* called *kerogen*. When crushed, it can be burnt directly [like coal] & has a heating value ranging from 2000 to 17,000 KJ/Kg. It is used in this manner for generating electricity & supplying heat.

Alternatively, the oil shale can be converted to oil. This is done by heating crushed oil shale to about 500 °c in the absence of air. Under the conditions, *pyrolysis* occurs & the kerogen is converted to oil.

Demerits:

- 1] The use of oil shale is the environmental degradation associated with surface mining & with the disposal of large amounts of sand & spent shale rock which remains after the crude oil is obtained.
- 2] A large amount of energy is consumed in producing oil from these sources.

NUCLEAR POWER:

Under the nuclear option, the 2 alternatives under study are,

1. The breeder reactor,

2. Nuclear fusion

1] The breeder reactor: In order to understand the working of a breeder reactor, it is necessary to understand the fission reactions. Naturally occurring uranium contains 3 isotopes, U^{234} , U^{235} & U^{238} . The relative % of these isotopes is U^{234} – 0.006%, U^{235} – 0.711% & U^{238} -99.283% of these isotopes, only U^{235} undergoes spontaneous fission when subjected to bombardment by slow neutrons. It is in fact that only naturally occurring fissile material.

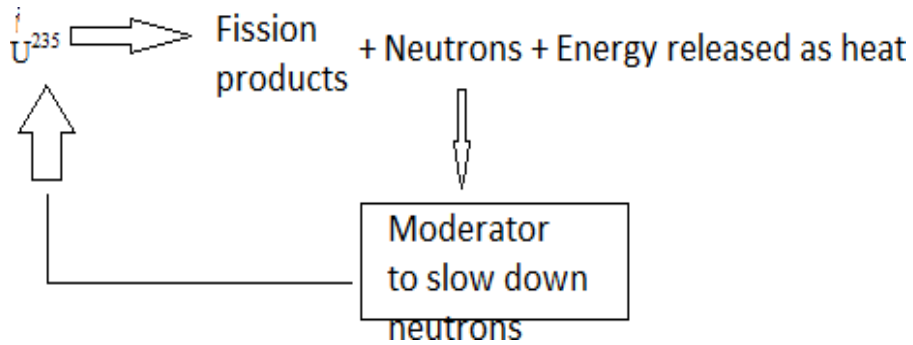

Fig. Fission reaction of U^{235}

The break-up of U^{235} when subjected neutrons & the release of a large amount of energy as heat [8.2×10^7 KJ/gm of U^{235}]. The neutrons are slowed down by a moderator, & used to bombard the U^{235} nucleus again, there by setting up a controlled chain reaction. Although U^{238} is not a fissile material, it is a fertile material, i.e., it can be converted by neutron bombardment into a fissile material, plutonium-239. Similarly, naturally-occurring thorium-232 is also a fertile material. It can be converted into U^{233} which is a fissile material.

It will be seen that the neutrons generated by the fission reaction serve two purposes. They help in converting a fertile material to a fissile material & also sustain the fission reaction for the fissile material formed. The above reactions are called *breeder reactions* if they produce more fissile material than they consume & the nuclear reactor in which they are caused to occur is called a *breeder reactor*.

Breeding is achieved by having both fissile & fertile materials in the reactor core under conditions which provide enough neutrons to propagate chain reactions in the fissile material as well as to convert more fertile material into fissile material than was originally present.

Reactors working on various breeder cycles have been built. However, the major effort has been on liquid-metal cooled, fast breeder reactors working on the U^{238} to Pu^{239} cycle.

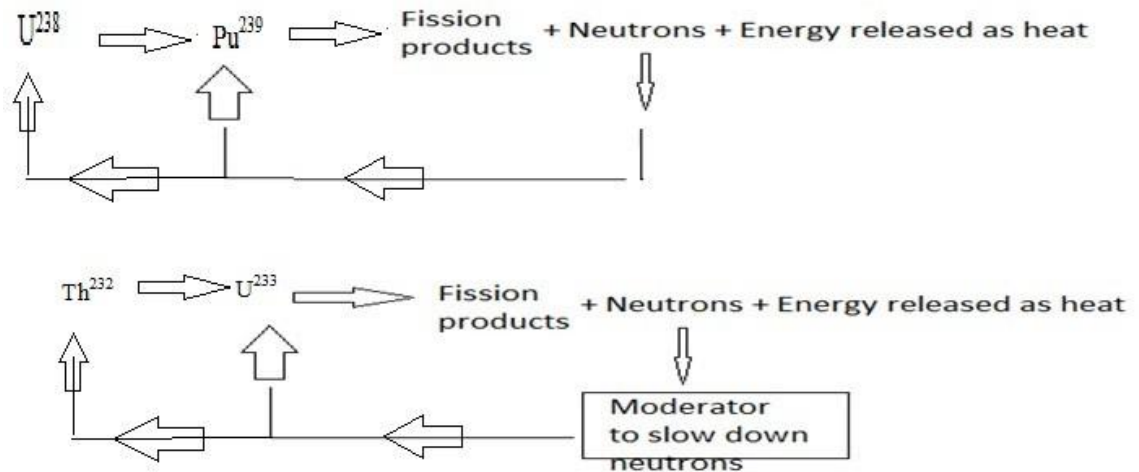
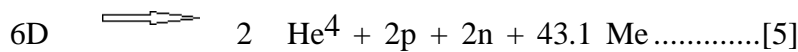

Fig.13. Breeder reactor for U^{238} & Th^{232}

NUCLEAR FUSION:

In nuclear fusion, energy is released by joining very light atoms. The reactions of interest involve the fusing of the heavy isotopes of hydrogen [deuterium D & tritium T] into the next heavier element, viz, helium. They are as follows.



Equation [1] & [2] show that 2 nuclei of deuterium can fuse in 2 ways. Both ways are equally probable. In the first, tritium & one proton are formed, while in the second, helium-3 & one neutron are formed. The energy released by the fusion reaction is indicated. Tritium is unstable & combines with deuterium to form helium-4 & one neutron, Equation [3], while helium-3 combines with deuterium to form helium-4 & one proton, Equation [4]. The net result Equation [5], is the addition of all the 4 reactions. It indicates that 6 deuterium nuclei are converted to 2 helium-4 nuclei, 2 protons & 2 neutrons with an energy release of 43.1 MeV.

Deuterium occurs naturally in sea water & it is estimated that the fusion of all the deuterium in just one cubic metre of sea water would yield energy of 12×10^9 KJ.

The development of nuclear fusion reactor are the attainment of the required high temperature by initially heating the fuel charge & the confinement of the heated fuel for a long enough time for the reaction to become self-sustaining.

The research being conducted to solve these problems is proceeding broadly along

2 conceptual directions- magnetic confinement & laser induced fusion.

In the first concept, the fuel charge [in the form of a charged particle gas composed of positively charged nuclei & free electrons] is contained in a hermetically sealed vacuum chamber & is heated to the required high temperature by passing an electric current through it. At this temperature, the fusion reaction takes place successfully only if the gas is confined within a certain volume for a specified time & not allowed to come into contact with containing chamber's walls. This confinement is achieved by the application of a very strong, specially shaped magnetic field.

In the second concept, the fuel charge in the form of very small pellets. These are positioned one by one at a specific location & subjected to intense focused laser beams which heat the pellets to the required temperature & cause fusion to occur. By adopting this method, the confinement time is substantially reduced & the need for a magnetic field is removed.

Of the reactions given in equation [1] to [4], the D-T reaction takes place at the lowest temperature; about 10^7 K. since tritium does not occur naturally, the D-T reaction should be supplemented by one using lithium as follows:

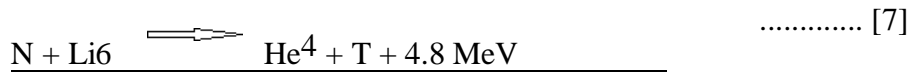

Solar-Radiation

Solar Radiation Outside the Earth's Surface

Sun is a large sphere of very hot gases; the heat being generated by various kinds of fusion reactions. Its diameter is 1.39×10^6 km, while that of the earth is 1.27×10^4 km. It subtends an angle of 32 minutes at the earth's surface. This is because it is also at large distance. Thus the beam radiation received from the sun on the earth is almost parallel. The brightness of the sun varies from its center to its edge. However, for engineering calculations. It is customary to assume that the brightness all over the solar disc uniform.

Solar Constant(I_{sc}):

It is the rate at which energy is received from the sun on a unit area perpendicular to the rays of the sun, at the mean distance of the earth from the sun. Based on the measurements made up to 1970 a standard value of 1353 W/m^2 was adopted in 1971. However, based on subsequent measurements, a revised value of 1367 W/m^2 has been recommended.

The earth revolves around the sun in an elliptical orbit having a very small eccentricity and the sun at the foci. Consequently, the distance between earth and sun varies a little through the year. Because of this variation, the extra-terrestrial flux also varies. The value on any day can be calculated from the equation.

$$I'_{sc} = I_{sc} \left\{ I + 0.033 \cos \frac{360n}{365} \right\}$$

Solar Radiation Received at the Earth's surface:

Solar radiation received at the earth's surface is in the attenuated form because it is subjected to the mechanisms of absorption and scattering as it passes through the earth's atmosphere (Figure below).

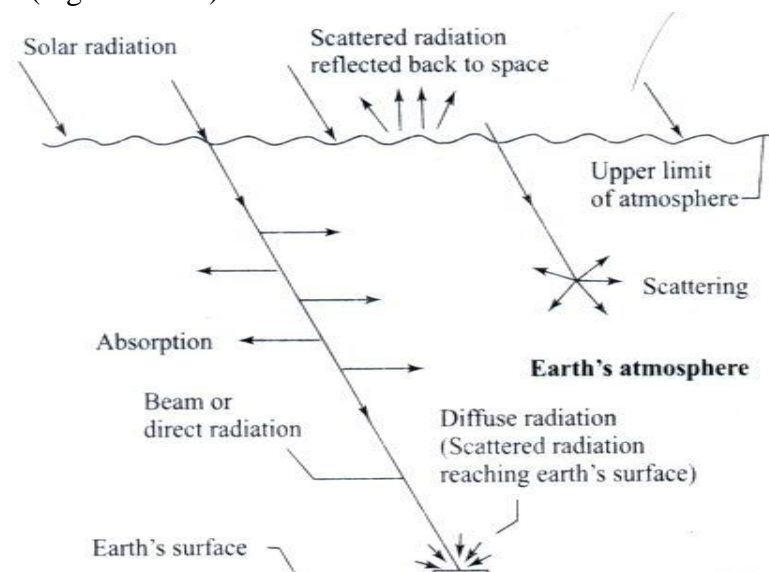

Absorption occurs primarily because of the presence of ozone and water vapour in the atmosphere and lesser extent due to other gases (like CO_2 , NO_2 , CO , O_2 and CH_4) and particulate matter. It results in an increase in the internal energy of the atmosphere. On the other hand, scattering occurs due to all gaseous molecules as well as particulate matter in the atmosphere. The scattered radiation is redistributed in all directions, some going back to the space and some reaching the earth's surface.

Solar radiation received at the earth's surface without change of direction i.e., in line with the sun is called *direct radiation* or *beam radiation*. The radiation received at the earth's surface from all parts of sky's hemisphere (after being subjected to scattering in the atmosphere) is called *diffuse radiation*. The sum of beam radiation and diffuse radiation is called as *total* or *global radiation*.

Instruments used for measuring solar radiation:

Pyrometer

A pyrometer is an instrument which measures either global or diffuse radiation falling on a horizontal surface over a hemispherical field of view. A sketch of one type of pyrometer as installed for measuring global radiation is shown in the following figure.

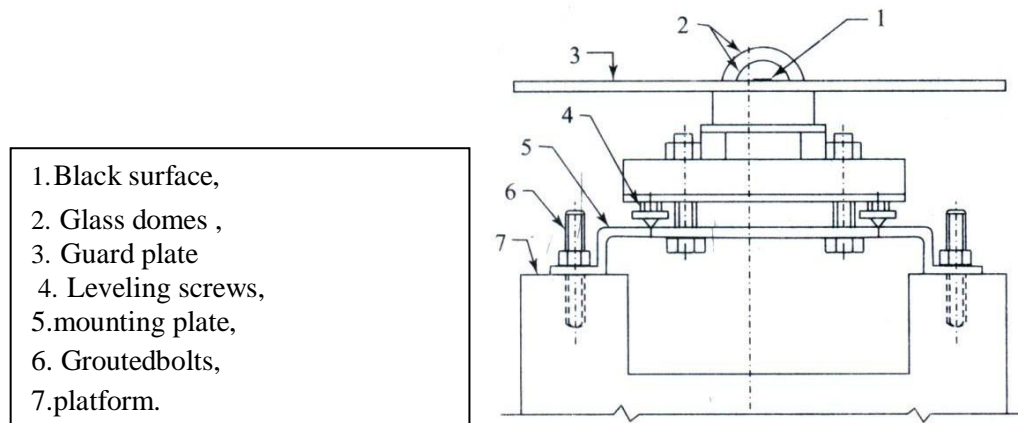

Pyrometer consists of a black surface which heats up when exposed to solar radiation. Its temperature increases until the rate of heat gain by solar radiation equals the rate of heat loss by convection, conduction and radiation. The hot junctions of thermopile are attached to the black surface, while the cold junctions are located under a guard plate so that they do not receive the radiation directly. As a result an emf is generated. This emf which is usually in the range of 0 to 10mv can be read, recorded or integrated over a period of time and is a measure of global radiation.

The pyrometer can also be used for measurement of diffuse radiation. This is done by mounting it at the center of a semi-circular shading ring. The shading ring is fixed in such a way that its plane is parallel to the plane of path of sun's daily movement across the sky and it shades the thermopile element and two glass domes of pyranometer at all the times from direct sun shine. Consequently the pyranometer measures only the diffuse radiation received from the sky.

Pyrheliometer:

This is an instrument which measures beam radiation falling on a surface normal to the sun's rays. In contrast to a pyranometer, the black absorber plate (with hot junctions of a thermopile attached to it) is located at the base of a collimating tube. The tube is aligned with the direction of the sun's rays with the help of a two-axis tracking mechanism and alignment indicator. Thus the black plate receives only beam radiation and a small amount of diffuse radiation falling within the acceptance angle of the instrument.

The Following figure shows a pyrliometer.

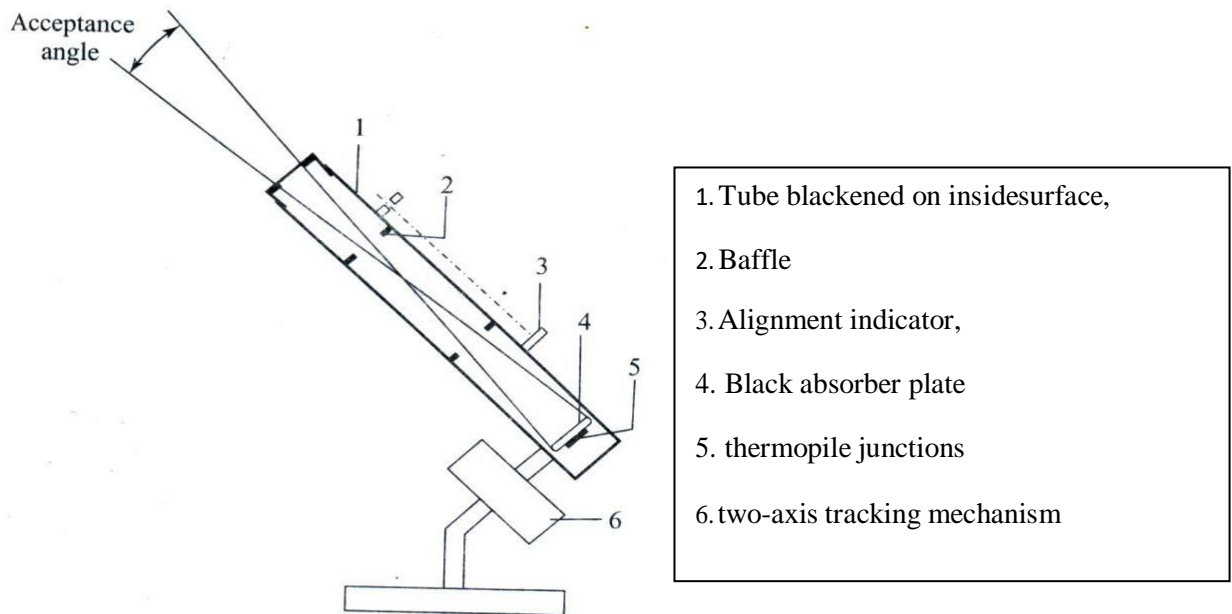

Solar Radiation Geometry

Definitions:

(a) Solar altitude angle(α):

Altitude Angle is the angle between the Sun's rays and projection of the Sun's rays on the horizontal plane

(b) Zenith angle(θ_z):

It is Complementary angle of Sun's Altitude angle

It is a vertical angle between Sun's rays and line perpendicular to the horizontal plane through the point i.e. angle between the beam and the vertical

$$\theta_z = \pi/2 - \alpha$$

(c) Solar Azimuth Angle(γ_s):

It is the solar angle in degrees along the horizon east or west of north

or

It is the horizontal angle measured from north to the horizontal projection of sun's rays.

(d) Declination(δ):

It is the angle between a line extending from the centre of the Sun and center of the earth and projection of this on earth's equatorial plane.

- Declination is the direct consequence of earth's tilt and It would vary between 23.5° on June 22 to -23.5° on December 22. On equinoxes of March 21 & Sept 22 declination is zero.
- The declination is given by the formula

$$\delta = 23.45 \sin \left\{ \frac{360}{365} (284 + n) \right\}$$

Where n is the day of the year

(e) Meridian:

Meridian is the imaginary line passing through a point or place on earth and north and south poles of the earth.

(f) Hour angle(ω):

Hour angle is the angle through which the earth must turn to bring meridian of the point directly in line with the sun's rays.

Hour angle is equal to 15° per hour.

(g) slope(β):

Angle between the collector surface with the horizontal plane is called slope(β).

(h) Surface azimuth angle(γ):

Angle between the normal to the collector and south direction is called surface azimuth angle(γ)

(i) Solar Incident angle(θ):

It is the angle between an incident beam radiation falling on the collector and normal to the plane surface

Figures:

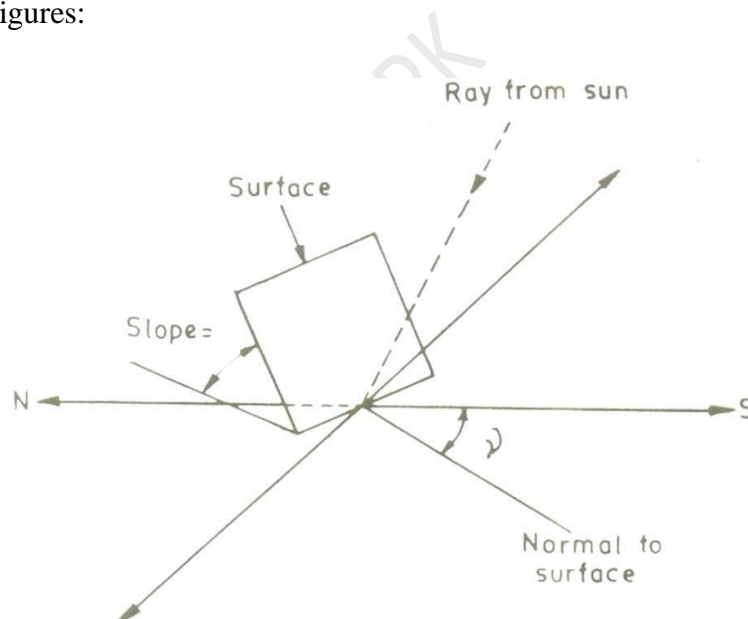

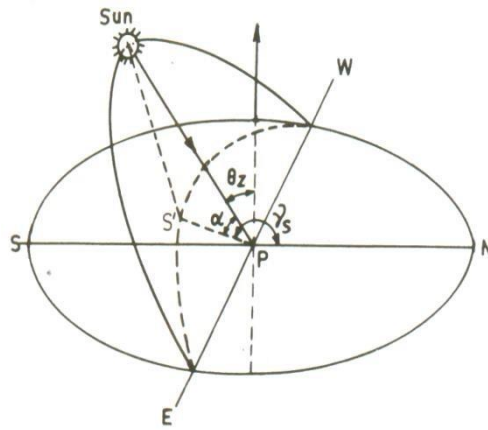

he plane surface.

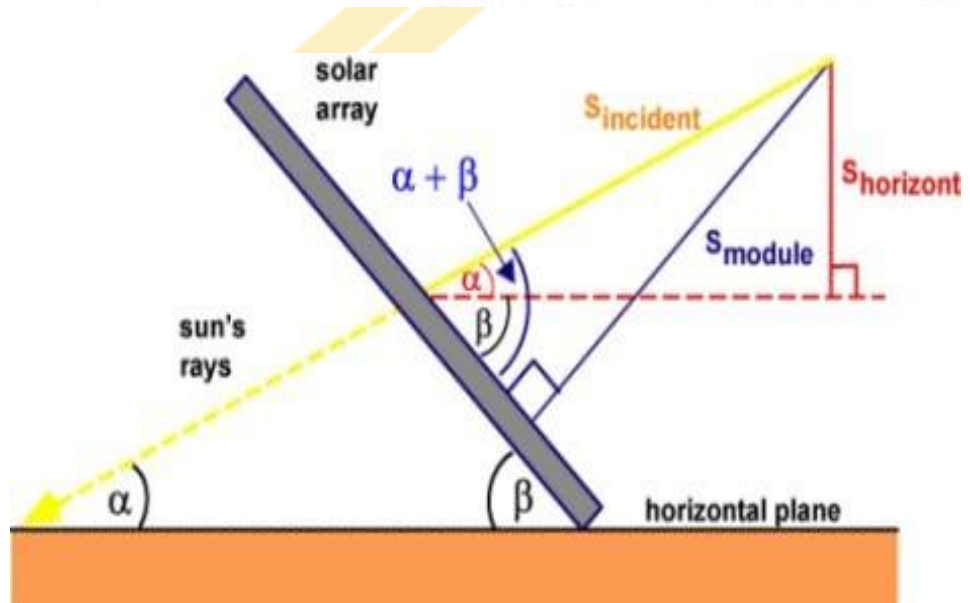
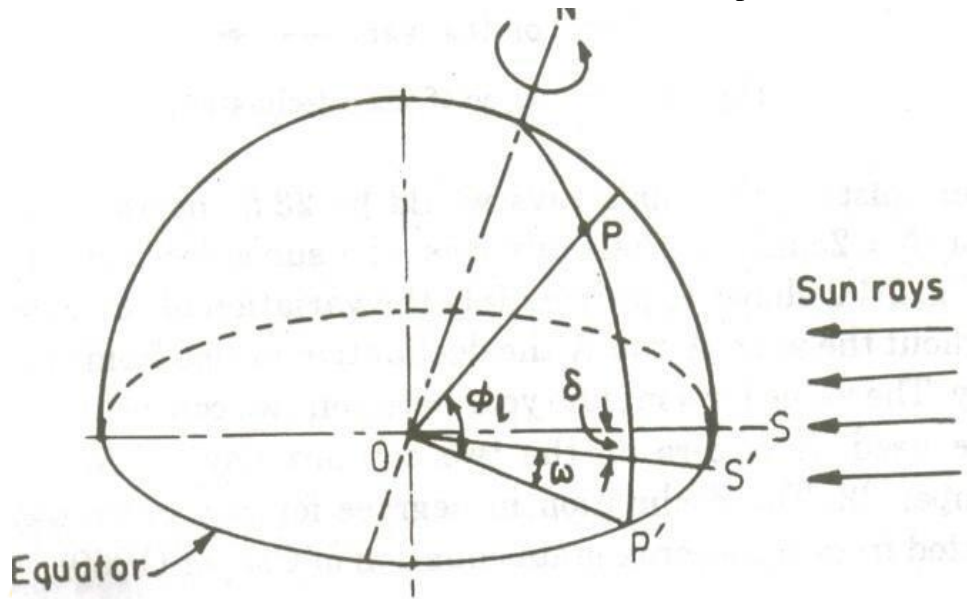

Relation between θ and other angles is as follows

$$\cos\theta = \sin\phi (\sin\delta \cos\beta + \cos\delta \cos\gamma \cos\omega \sin\beta) + \cos\phi (\cos\delta \cos\omega \cos\beta - \sin\delta \cos\gamma \sin\beta) + \cos\delta \sin\gamma \sin\omega \sin\beta \text{ ---- Eqn (1)}$$

ϕ =Latitude (north positive)

δ =declination (north positive)

ω =solar hour angle (Positive between midnight and solar noon)

Case1: Vertical Surface: $\beta=90^\circ$ Eqn (1) becomes

$$\cos\theta = \sin\phi \cos\delta \cos\gamma \cos\omega - \cos\phi \sin\delta \cos\gamma + \cos\delta \sin\gamma \sin\omega \text{ --- Eqn (2)}$$

Case2 Horizontal surfaces $\beta=0^\circ$ Eqn (1) becomes

$$\cos\theta = \sin\phi \sin\delta + \cos\delta \cos\phi \cos\omega = \sin\alpha = \cos\theta_z \text{----- Eqn (3)}$$

Case3 Surface facing south $\gamma = 0$

$$\begin{aligned} \cos\theta &= \sin\phi (\sin\delta \cos\beta + \cos\delta \cos\omega \sin\beta) \\ &= \cos\phi (\cos\delta \cos\omega \cos\beta - \sin\delta \sin\beta) \\ &= \sin\delta \sin(\phi - \beta) + \cos\delta \cos\omega \cos(\phi - \beta) \text{----- Eqn (4)} \end{aligned}$$

Case4 Vertical surfaces facing south ($\beta=90^\circ, \gamma=0$)

$$\cos\theta_z = \sin\phi \cos\delta \cos\omega - \cos\phi \sin\delta \text{ ----- Eqn (5)}$$

Day Length:

At the time of sunset or sunrise the zenith angle $\theta_z=90^\circ$, we obtain

sunrisehour angle as

$$\begin{aligned} \cos\omega_s &= -\frac{\sin\phi \sin\delta}{\cos\phi \cos\delta} = -\tan\phi \tan\delta \\ \omega_s &= \cos^{-1}\{-\tan\phi \tan\delta\} \end{aligned}$$

Since 15° of the hour angle are equivalent to 1 hour The

daylength(hrs) is given by

$$td = \frac{2\omega}{15} = \frac{2}{15} \cos^{-1} - \{\tan\phi \tan\delta\}$$

Local Solar Time (Local Apparent Time (LAT)):

Local Solar Time can be calculated from standard time by applying two corrections. The first correction arises due to the difference in longitude of the location and meridian on which standard time is based. The correction has a magnitude of 4minutes for every degree difference in longitude. Second correction called the equation of time correction is due to the fact that earth 's orbit and the rate of rotation are subject to small perturbations. This is based on the experimental observations.

Thus,

Local Solar Time=Standard time \pm 4(Standard time Longitude-Longitude of the location) + (Equation of time correction)

Example 1:

Determine the local solar time and declination at a location latitude 23^o15'N, longitude 77^o30'E at 12.30 IST on june 19. Equation of Time correction is =

-(1'01").

Solution:

The Local solar time=IST- (standard time longitude-longitude of location) +
Equation of time correction.

$$=12^{\text{h}}30' - 4(82^{\circ}30' - 77^{\circ}30') - 1'01''$$

$$=12^{\text{h}}8'59''$$

Declination δ can be calculated Cooper's Equation i.e.,

$$\begin{aligned} \delta &= 23.45 \sin \left\{ \frac{360}{365} (284 + n) \right\} \\ &= 23.45 \sin \left\{ \frac{360}{365} (284 + 170) \right\} = 23.45 \sin 86^{\circ} = 23.43^{\circ} \end{aligned}$$

Example 2: Calculate an angle made by beam radiation with normal to a flat plate collector on December 1 at 9.00 A.M, Solar time for a location at $28^{\circ}35'N$. The collector is tilted at an angle of latitude plus 10° , with the horizontal and is pointing due south.

Solution:

Here $\gamma=0$ since collector is pointing due south. For this case we have equation.

$$\cos \theta_{\theta T} = \sin \delta \sin(\phi - \beta) + \cos \delta \cos \omega \cos(\phi - \beta)$$

Declination δ can be calculated Cooper 's Equation on December 1st i.e, $n=335$

$$\delta = 23.45 \sin \left\{ \frac{360}{365} (284 + n) \right\}$$

$$= 23.45 \sin \left\{ \frac{360}{365} (284 + 335) \right\} = -22^{\circ}11''$$

Hour angle ω corresponding to 9.00hr= 45°

Hence,

$$\cos \theta_{\theta T} = \cos (28.58^{\circ} - 38.58^{\circ}) \cos (-22.11^{\circ}) \cos 45^{\circ} +$$

$$\sin (-22.11^{\circ}) \sin (28.58^{\circ} - 38.58^{\circ}) = 0.7104$$

$$\theta_{\theta T} = 44.72^{\circ}$$

Module-2

Solar Radiation Geometry

(a) Solar altitude angle(α):

Altitude Angle is the angle between the Sun's rays and projection of the Sun's rays on the horizontal plane.

(b) Zenith angle (θ_z):

It is Complementary angle of Sun's Altitude angle.

It is a vertical angle between Sun's rays and line perpendicular to the horizontal plane through the point i.e. angle between the beam and the vertical.

$$\Theta_z = \pi/2 - \alpha$$

(c) Solar Azimuth Angle (γ_s):

It is the solar angle in degrees along the horizon east or west of north.

or

It is the horizontal angle measured from north to the horizontal projection of sun's rays.

(d) Declination (δ):

It is the angle between a line extending from the center of the Sun and center of the earth and projection of this on earth's equatorial plane.

➤ Declination is the direct consequence of earth's tilt and It would vary between 23.5° on June 22 to -23.5° on December

22. On equinoxes of March 21 & Sept 22 declination is zero.

➤ The declination is given by the formula

$$\delta = 23.45 \sin \left\{ \frac{360}{365} (284 + n) \right\}$$

Where n is the day of the year

(e) Meridian:

Meridian is the imaginary line passing through a point or place on earth and north and south poles of the earth.

(f) Hour angle (ω):

Hour angle is the angle through which the earth must turn to bring meridian of the point directly in line with the sun's rays. Hour angle is equal to 15° per hour.

(g) slope(β):

Angle between the collector surfaces with the horizontal plane is called slope (β).

(h) surface azimuth angle(γ):

Angle between the normal to the collector and south direction is called surface azimuth angle (γ)

(i) Solar Incident angle(θ):

It is the angle between an incident beam radiation falling on the collector and normal to the plane surface

Figures:

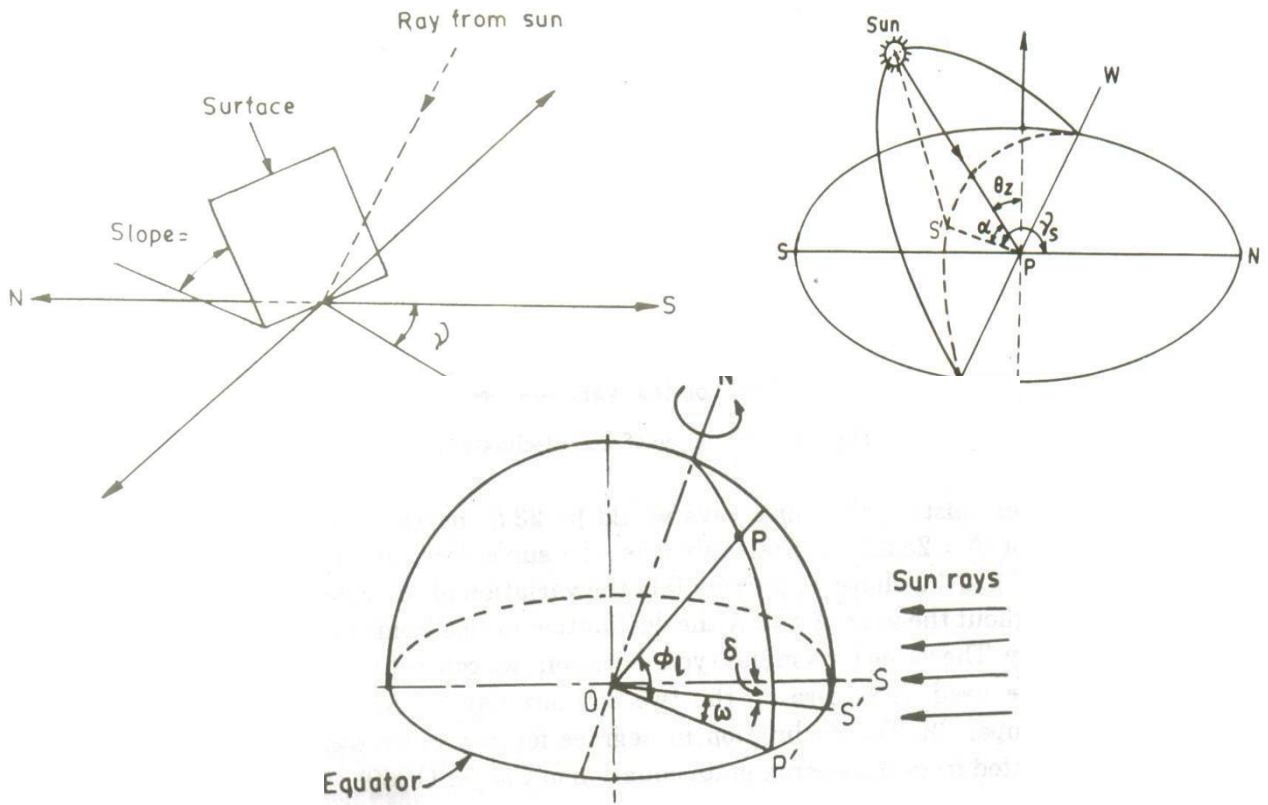

Relation between θ and other angles is as follows

$$\cos\theta = \sin\phi_l (\sin\delta \cos\beta + \cos\delta \cos\gamma \cos\omega \sin\beta) + \cos\phi_l (\cos\delta \cos\omega \cos\beta - \sin\delta \cos\gamma \sin\beta) + \cos\delta \sin\gamma \sin\omega \sin\beta \text{ ---- Eqn(1)}$$

ϕ_l =Latitude (north positive) δ =declination (north positive)

ω =solar hour angle (Positive between midnight and solar noon)

➤ **Case1 Vertical Surface:**

$\beta=90^\circ$ Eqn (1) becomes

$$\cos\theta = \sin\phi \cos\delta \cos\gamma \cos\omega - \cos\phi \sin\delta \cos\gamma + \cos\delta \sin\gamma \sin\omega \text{ ---- Eqn (2)}$$

➤ **Case2 Horizontal surfaces $\beta=0^\circ$, Eqn(1) becomes**

$$\cos\theta = \sin\phi \sin\delta + \cos\delta \cos\phi \cos\omega = \sin\alpha = \cos\theta_z \text{ ----Eqn (3)}$$

➤ **Case3**

Surface facing south $\gamma = 0$

$$\begin{aligned}\cos \theta_T &= \sin \phi (\sin \delta \cos \beta + \cos \delta \cos \omega \sin \beta) \\ &= \cos \phi (\cos \delta \cos \omega \cos \beta - \sin \delta \sin \beta) \\ &= \sin \delta \sin(\phi - \beta) + \cos \delta \cos \omega \cos(\phi - \beta) \text{----- Eqn (4)}\end{aligned}$$

➤ **Case4**

Vertical surfaces facing south ($\beta=90^\circ$, $\gamma=0$)

$$\cos \theta_z = \sin \phi \cos \delta \cos \omega - \cos \phi \sin \delta \text{----- Eqn (5)}$$

Day Length: At the time of sunset or sunrise the zenith angle $\theta_z=90^\circ$, we obtain sunrise hour angle as

$$\begin{aligned}\cos \omega_s &= -\frac{\sin \phi \sin \delta}{\cos \phi \cos \delta} = -\tan \phi \tan \delta \\ \omega_s &= \cos^{-1}\{-\tan \phi \tan \delta\}\end{aligned}$$

Since 15° of the hour angle are equivalent to 1 hour The day length (hrs) is given by

Local Solar Time (Local Apparent Time (LAT):

$$td = \frac{2\omega}{15} = \frac{2}{15} \cos^{-1} - \{ \tan \phi \tan \delta \}$$

Local Solar Time can be calculated from standard time by applying two corrections. The first correction arises due to the difference in longitude of the location and meridian on which standard time is based. The correction has a magnitude of 4 minutes for every degree difference in longitude. Second correction called the equation of time correction is due to the fact that earth's orbit and the rate of rotation are subject to small perturbations. This is based on the experimental observations.

Thus, Local Solar Time = Standard time \pm 4(Standard time Longitude - Longitude of the location) + (Equation of time correction)

Example 1:

Determine the local solar time and declination at a location latitude $23^\circ 15' N$, longitude $77^\circ 30' E$ at 12.30 IST on June 19. Equation of Time correction is $-(1' 01'')$.

Solution:

The Local solar time = IST - (standard time longitude - longitude of location) + Equation of time correction.

$$= 12^{\text{h}} 30' - 4(82^\circ 30' - 77^\circ 30') - 1' 01''$$

$$= 12^{\text{h}} 8' 59''$$

Declination δ can be calculated Cooper's Equation i.e.,

$$\delta = 23.45 \sin \left\{ \frac{360}{365} (284 + n) \right\}$$

360

$$= 23.45 \sin \frac{(284 + 170)}{365} = 23.45 \sin 86^\circ = 23.43^\circ$$

Beam Radiation:

Tilt factor (R_b): The ratio of beam radiation flux falling on the tilted surface to that of horizontal surface is called the TILT FACTOR for beam radiation.

For case of tilted surface facing due south $\gamma=0$

$$\cos \theta = \sin \delta \sin (\phi - \beta) + \cos \delta \cos \omega \cos (\phi - \beta)$$

while for a horizontal surface

$$\cos \theta_z = \sin \phi \sin \delta + \cos \phi \cos \delta \cos \omega$$

Hence
$$r_b = \frac{\cos \theta}{\cos \theta_z} = \frac{\sin \delta \sin (\phi - \beta) + \cos \delta \cos \omega \cos (\phi - \beta)}{\sin \phi \sin \delta + \cos \phi \cos \delta \cos \omega}$$

Diffuse Radiation:

Tilt factor (r_d): The ratio of diffuse radiation flux falling on the tilted surface to that of horizontal surface is called the tilt factor for diffuse radiation.

Its value depends on the distribution of diffuse radiation over the sky and the portion of the sky dome seen by the tilted surface.

Assuming that the sky is an isotropic source of diffuse radiation, for a tilted surface with slope β , we have

$$r_d = \frac{1 + \cos \beta}{2}$$

$(1 + \cos \beta)/2$ is the shape factor for a tilted surface w.r.t. sky

For Total radiation, let H_b=Hourly beam radiation and H_d=Hourly diffuse radiation.

Thus the total beam radiation incident on a tilted surface is given as,

$$H_T = H_b R_b + \frac{(1 + \cos S)}{2} + \frac{(H_b + H_d)(1 - \cos S)}{2} \rho$$

ρ = diffuse reflectance which is used to account for the reradiated

Solar collectors:

Solar collectors are the devices used to collect solar radiation. Generally there are two types of solar collectors. They are 1) Non-conventional type or Flat plate collector and 2) Concentrating or Focusing collector.

In a non-concentrating type the area of the absorber is equals the area of the collector and since the radiation is not focused, the maximum temp achieved in this type is about 100° C. on the other hand in a concentrating type the area of the absorber is very small (50-100 times) as compared to the collector area. This results in less loss of heat and also since the radiation is focused to a point

or a line the maximum temp achieved is about 350°C.

Principle of solar energy conversion to heat:

The principle on which the solar energy is converted into heat is the greenhouse effect. The name is derived from the first application of greenhouses in which it is possible to grow vegetation in cold climate through the better utilization of the available sunlight. The solar radiation incident on the earth's surface at a particular wavelength increases the surface temp of the earth. As a result of difference in temp between the earth's surface and the surroundings, the absorbed radiation is reradiated back to the atmosphere with its wavelength increased. The CO₂ gas in the atmosphere is transparent to the incoming shorter wavelength solar radiation, while it is opaque to the long wavelength reradiated radiation. As a result of this the long wavelength radiation gets reflected repeatedly between the earth's atmosphere and the earth's surface resulting in the increase in temp of the earth's surface. This is known as the —Green House Effect. This is the principle by which solar energy is converted to thermal energy using collector.

In a flat plate collector the absorber plate which is a black metal plate absorbs the radiation incident through the glass covers. The temp of the absorber plate increases and it begins to emit radiation of longer wavelength (IR). This long wavelength radiation is blocked from the glass covers which act like the CO₂ layer in the atmosphere. This repeated reflection of radiation between the covers and the absorber plate results in the rise of the temp of the absorber plate

Flat plate collector (FPC):

The schematic diagram of a FPC is as shown in fig. it consists of a casing either made up of wood or plastic having an area of about 2m*1m*15cm. in the casing insulator is provided at the bottom to check conductive heat transfer. Mineral wool, glass wool, fiber glass, asbestos thermocol etc. are used as insulator. Above the insulator the absorber plate is fixed. The absorber plate is made of good conducting material like aluminum or copper. It is coated black to increase its absorption property. Usually the black coating is done by chemical treatment. Selective coatings which allow for maximum absorption of radiation and minimum amount of emission are applied on to the absorber plate. The underside of the plate consists of absorber tubes which run along the length of the plate. These plates are also made of the same material as that of the absorber plate. Sometimes the plate itself is bent into the form of tubes. Through these tubes the heat absorbing medium (water) is circulated. This medium will absorb the heat from the plates and the tubes and its temp increases. This medium will absorb the heat from the plates and the tubes and its temperature increases. This way solar energy is collected as heat energy. Above the absorber plate glass covers are provided. These glass covers help to bring out the greenhouse effect, thus increasing the η of the collector. More than one cover is used to prevent the loss of radiation by refraction.

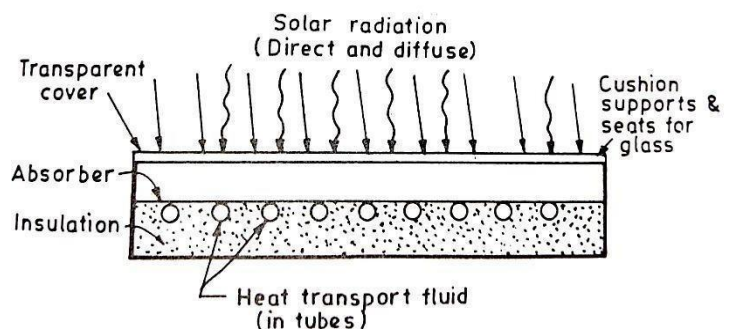

Fig. 3.3.1. Selection through typical flat-plate collector.

BASIC HOT AIR SYSTEM:

Schematic diagram of a basic hot air heating system is shown in Fig.5.3.6. In this system the storage medium is held in the storage unit, while air is the fluid used to transport energy from collector to the storage and to the building. By adjusting the dampers, the heated air from the collector can be divided between rock storage and the distribution system, as might be required

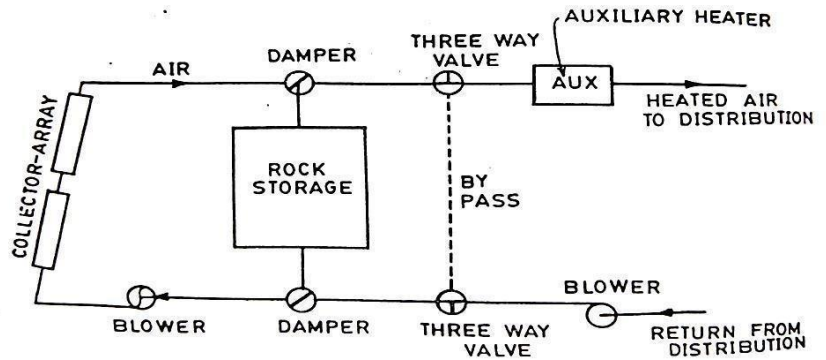

Fig. 5.3.6. Schematic diagram of a basic hot air heating system.

by the conditions. For example, when the sun shines after several cloudy days it would be desirable to utilize the available heat directly in the distribution system rather than placing it in storage. Two three way valves can be used to bypass the storage tank, as explained above. An auxiliary source of heating is also provided. Auxiliary heating can be used to augment the energy supply to the building from the collector or storage if the supply of heat from it is inadequate.

The position of the blower in figure is shown at the upstream of the collector and the storage, and it forces the air through these for heating. In this case slight leakage of heated air will take place. Blower can also be placed on the downstream side of the collector and storage, so that the pressure in the collector is not above ambient pressure, which might be advantageous in controlling leakage.

Concentrating collectors: These are the solar collectors where the radiation is focused either to a point (focal point of the collector) or along a line (focal axis of the collector). Since the radiation is focused, the η of concentrating collector is always greater than that of non-focusing or FPC. This is because of the following reasons,

- 1) In case of focusing collector the area of the absorber is many times smaller than that of the area of the collector. Where as in a non-concentrating type the area of the absorber equals area of the collector. Hence here the loss of absorbed radiation is more compared to the concentrating type.
- 2) In a concentrating collector since the radiation is focused, its intensity is always greater than that in the non-focusing type. Because of these reasons the concentrating collectors are always used for high temp applications like power generation and industrial process heating.

Classification of concentrating collectors:

1. Focusing type
 - Line focusing
 - Parabolic trough collector
 - cylindrical parabolic
 - Mirror strip collector

- Fresnal lense collector
- Point focusing
 - Parabolidal collector
 - central tower concept
- 2. Non Focusing type
 - Mirror boosting collector
 - Compound parabolic concentrator

Compound Parabolic Concentrator

Compound Parabolic Concentrator consists of two parabolic mirror segments, attached to a flat receiver. The segments are oriented such that the focus of one is located at the bottom end point of the other in contact with the receiver. It has a large acceptance angle and needs to be adjusted intermittently. Rays in the central region of the aperture reach the absorber directly whereas, those near the edges undergo one or more reflections before reaching the absorber. The concentration ratio achieved from this collector is in the range of 3-7.

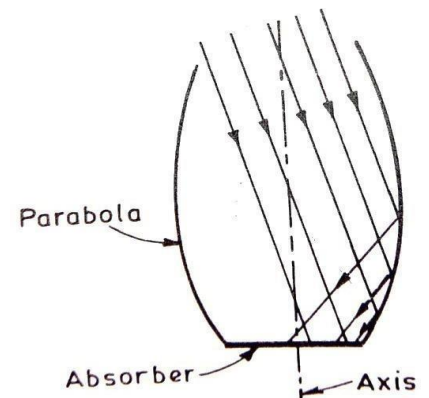
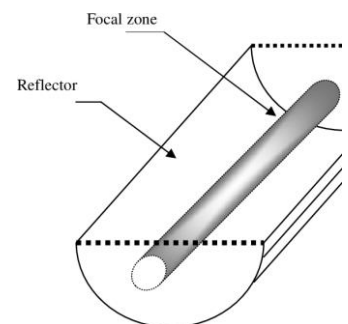

Fig. 3.7.10. Compound parabolic concentrator.

Cylindrical Parabolic Concentrator

It consists of a cylindrical parabolic through reflector and a metal tube receiver at its focal line as shown in figure above. The receiver tube is blackened at the outside surface to increase absorption. It is rotated about one axis to track the sun. The heat transfer fluid flows through the receiver tube, carrying the thermal energy to the next stage of the system. This type of collector may be oriented in any one of the three directions: East-West, North-South or polar. The polar configuration intercepts more solar radiation per unit area as compared to other modes and thus gives best performance. The concentration ratio in the range of 5-30 may be achieved from these collectors.



Parabolidal Dish Collector:

When a parabola is rotated about its optical axis a Parabolidal surface is produced. Above figure shows the details of this type of collector. Beam radiation is focused at a point in the paraboloid. This requires two axis tracking. It can have concentration ratio ranging from 10 to few thousands and can yield temperature up to 3000oC. Parabolidal dish collectors of 6- 7m in diameter are commercially manufactured.

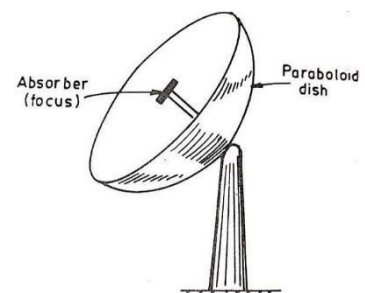

Fig. 3.7.7. Point focus solar collector (Paraboloid).

Solar energy storage systems:

The thermal energy of sun can be stored in a well-insulated fluids or solids. It is either stored as i) **sensible heat** – by virtue of the heat capacity of the storage medium, or as ii) **Latent heat** – by virtue of the latent heat of change of phase of the medium or both.

In the first type of storage the temp of the medium changes during charging or discharging of the storage whereas in the second type the temp of the medium remains more or less constant since it undergoes a phase transformation.

An overview of the major techniques of storage of solar energy is as shown in the fig. A wide range of technical options are available for storing low temp thermal energy as shown. Some of the desired characteristics of the thermal energy as shown below. Some of the different storage techniques and their main features are compared in the next table. Desired properties of phase change heat storage materials are also listed in subsequent table.

WATER HEATING SOLAR SYSTEM

NATURAL CIRCULATION SOLAR WATER HEATER (PRESSURIZED):

A natural circulation system is shown in Fig. 5.2.1. It consists of a tilted collector with transparent cover glasses, a separate highly insulated water storage tank, and well insulated pipes connecting the two. The bottom of the tank is at least 1ft the top of the collector, and no auxiliary energy is required to circulate water through it. The density difference between the hot and cold water thus provides the driving force for the circulation of water through the collector and the storage tank.

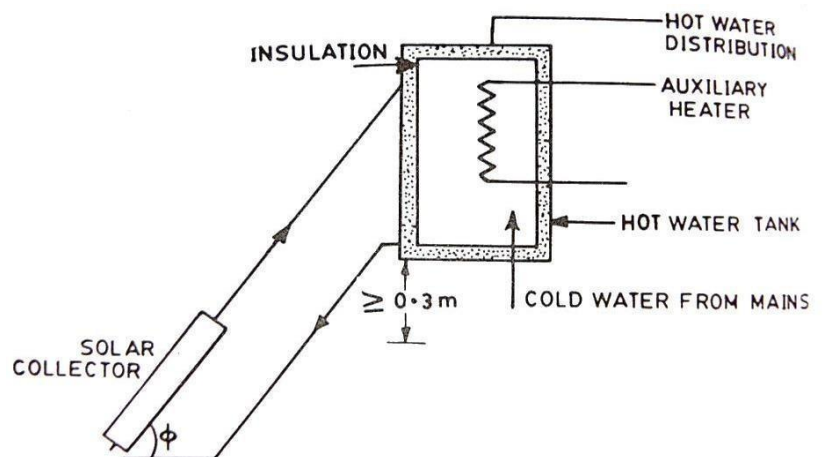

Fig. 5.2.1. Schematic of a neutral circulation solar water heater (pressurized).

Hot water is drawn off from the top of the tank as required and is replaced by cold water from the service system. As long as the sun shines the water will quietly circulate, getting warmer. After sunset, a thermosiphon system can reverse its flow direction and loss heat to the environment during the night. The thermosiphon system is one of the least expensive solar hot-water systems and should be used whenever possible. Thermosiphon solar water heaters are passive systems and do not require a mechanical pump to circulate the water. Such heaters can be used extensively in rural areas, where electricity is expensive and there is little danger of freezing.

NATURAL CIRCULATION SOLAR WATER HEATER (NON-PRESSURIZED)

The pressurized system is able to supply hot water at locations of the storage tank. This creates considerable stress on the water channels in the collector which must be designed accordingly. The non-pressurized systems supply hot water by gravity flow only to users lower than tank. If pressurized hot water is required (for showers, or appliances) the difference in

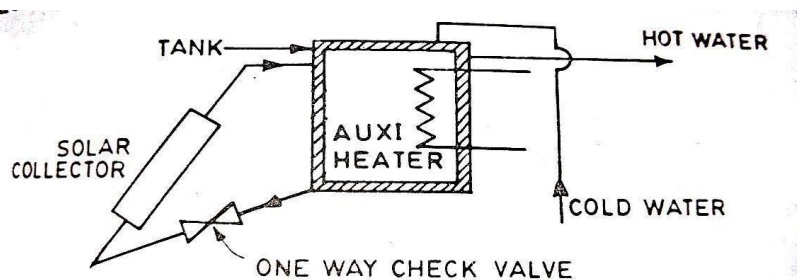

Fig. 5.2.2. Non-pressurized solar water heater.

height will have to be large enough to meet the requirements. If the height of difference cannot be accommodated, the only solution is to install a separate pump and pressure tank. The stresses within non-pressurized system are lower which allows cheaper and easier construction. In this type also mechanical pump is not required as shown in Fig.5.2.2.

FORCED CIRCULATION SOLARE WATER HEATER (WITHOUT ANTIFREEZE):

Fig.5.2.4 shows schematically an example of forced circulation system. By including an electric pump in the return circuit between the bottom of the storage tank and the lower header of the collector, the tank can be placed at a more convenient level (e.g. in the house basement). This is now an active system. A control unit permits the pump to operate only when the temperature of the water at the bottom of the tank is below that of the water in the upper header. A check valve is needed to prevent reverse circulation and resultant night time thermal losses from the collector. In this example, auxiliary heater is shown as provided to the water leaving the tank and going to the load.

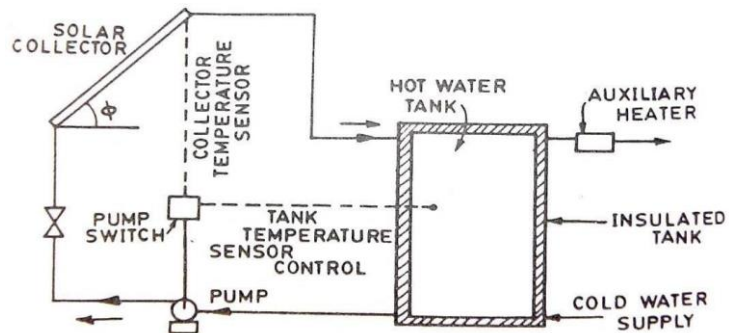

Fig. 5.2.4. Schematic of a forced circulation solar water heater.

When there is a danger of freezing, the water may be drained from the collector; alternately, a slow reverse flow of the warmer water may be permitted through the collector on cold nights. The freezing danger can be overcome, although at some increase in cost, by using an antifreeze solution as the heat-transport medium, as described earlier. The heat is then transferred to water in the storage tank by way of a heat exchanger coil.

When there is a danger of freezing, the water may be drained from the collector; alternately, a slow reverse flow of the warmer water may be permitted through the collector on cold nights. The freezing danger can be overcome, although at some increase in cost, by using an antifreeze solution as the heat-transport medium, as described earlier. The heat is then transferred to water in the storage tank by way of a heat exchanger coil.

FORCED CIRCULATION SOLAR WATER HEATER (WITH ANTIFREEZE):

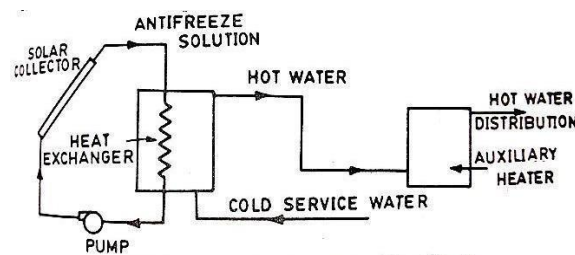

Fig. 5.2.5. Solar water heating system with antifreeze.

SPACE-HEATING:

SOLAR HEATING OF BUILDING:

A sunspace is any enclosed space, such as a green house or sun porch, with a glass wall on the south side. A sunspace may be attached (or built on) to a thick south wall of the building to be heated by the sun. Vents near the top and bottom of the wall, as in Fig. 5.3.1, permit circulation through the main building of the heated in the sunspace. Heat storage is provided by the thick wall, a concrete or masonry floor, water containers, and other materials in the sunspace. Thus, an attached sunspace system combines

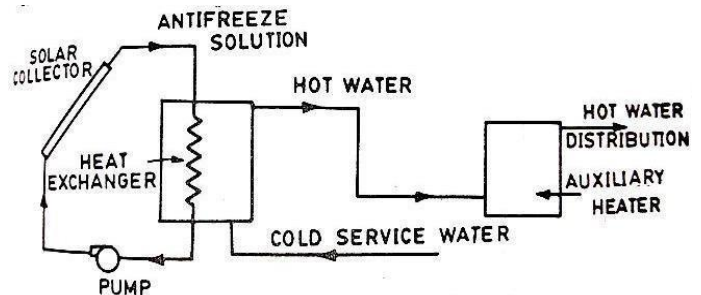

Fig. 5.2.5. Solar water heating system with antifreeze.

features of direct gain and storage wall concepts.

Roof storage of solar heat:

A passive solar system, trade named sky therm, was designed for house having a flat roof located in a mild climate. The heat is absorbed and stored in water about 0.25 m deep contained in plastic bags held in blackened steel boxes on the house roof. In a later design, a layer of clear plastic sealed to the top of the bag provides a stagnant airspace to reduce heat losses to the atmosphere. Heat is transferred from the heated water to the rooms below by conduction through a metal ceiling. Air circulation may be aided by means of electric fans, but this is not essential. To prevent loss of heat during the night, thermal insulator panels are moved, either manually or by a time controlled electric motor, to cover the water bags. In the day time, the panels, which are in sections, are removed and stacked one above the other.

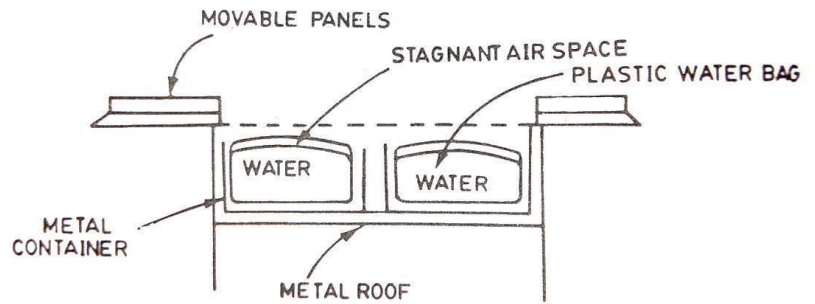

Fig. 5.3.2. Roof storage of Solar heat.

Basic hot water active system:

An outline of an active heating system with a sloping flat plate collector located on the roof of the building is given in Fig.5.3.4. This is a basic hot water heating system, with water tank storage and auxiliary energy source. Heat is transferred to the water in the storage tank, commonly located in the basement of the building. The solar heated water from the tank passes through an auxiliary heater, which comes on automatically when the water temperature falls below a prescribed level. For space heating, the water may be pumped through radiators or it may be used to heat air in a water to air heat exchanger.

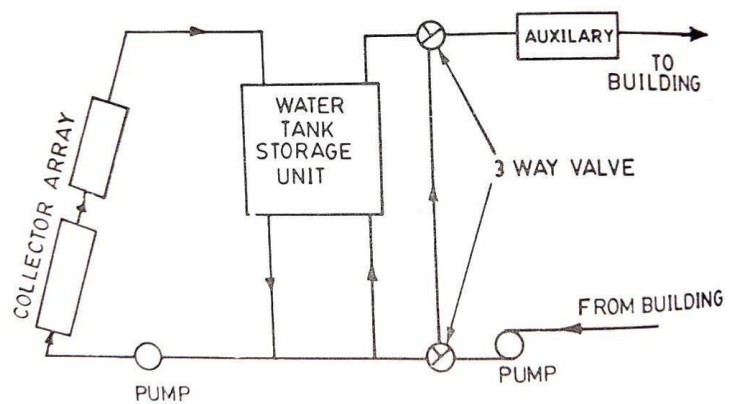

Fig. 5.3.4. Schematic of a basic hot water active system.

During normal operation, the three way valves are set to permit solar heated water to flow from the storage tank and auxiliary heater to the distribution system and back to the tank. If after several cloudy days, the heat in storage is depleted, the valves will adjust automatically to bypass the storage tank. In this way, auxiliary heating of the large volume of water in the tank is prevented. If the temperature in the heater at the top of the collector should fall below that at the bottom of the tank, the pump would be switched off automatically.

SOLAR SPACE COOLING OF BUILDINGS: VAPOUR ABSORPTION AIR COOLING (LiBr-H₂O SYSTEM 85 to 95°C with FPC /NH₃-H₂O COOLER 120 to 130°C with concentrating collectors):

The absorption air conditioning system is shown schematically in Fig.5.4.1.

The system consists of two parts
 (i) The solar collector and storage, and
 (ii) The absorption air conditioner and the auxiliary heating.

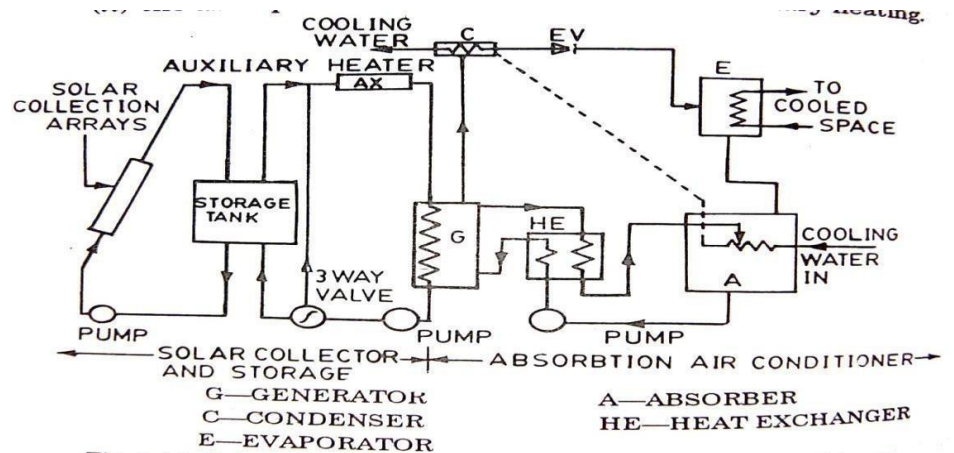

Fig. 5.4.1. Schematic of Solar Operated Absorption Air Conditioner.

The essential components of the cooler are (i) generator (G), (ii) condenser (C), (iii) evaporator (E), (iv) absorber (A), (v) heat-exchanger (HE).

The operation of air conditioners with energy from flat-plate collector and storage systems is the most common approach to the solar cooling today. In essence cooling is accomplished as the generator of the absorption cooler is supplied with heat by a fluid pumped from the collector storage system or from auxiliary. Heat is supplied to a solution of refrigerant in absorbent in the generator, where refrigerant is distilled out of the absorbent fluid. The refrigerant is condensed and goes through a pressure reducing valve to the evaporator where it operates and cools air or water for the cooling space. The refrigerant vapor goes to the absorber where it comes in contact with the solution which is weak in refrigerant and which flows from the generator. The vapor is absorbed in the solution, which is then returned to the generator. A heat exchanger is used for sensible heat recovery and greatly improves cooler C.O.P. From the point of view of use of a conventional energy source, there is a single index of performance for rating cooling processes that is the COP the ratio of the amount of cooling to the energy required. For solar operation there are two additional factors, the temperature required in the solar collector to drive the process and the ratio of cooling produced to solar energy incident on the collector. As solar processes are inevitably transient in their operation, the energy ratios and temperatures will vary with time and COP based on long term integrated performance provides an appropriate index of performance. Pumping to more absorbent solution may be by mechanical means or by vapor-lift pumping in the generator for low pressure systems like LiBr-H₂O system require water cooling of absorber and condenser. Systems of this type shown in the figure have been the basis of most of the experience to date with solar air conditioning.

The coolers used in most experiments to date are LiBr-H₂O machines water-cooled absorber and condenser. The pressure in the condenser and generator is fixed largely by temperature drops across heat transfer surfaces in the generator and condenser. The pressure in the evaporator and absorber is fixed by the temperature of the cooling fluid to the absorber and by the temperature drop across the heat transfer surfaces in the evaporator and the absorber. Thus, to keep the generator temperatures within the limits imposed by the characteristics of flat-plate collector, the critical design factors and operational parameters include effectiveness of the heat exchangers and coolant temperature. Common practice in solar experiments has been to use water cooled absorbers and condensers, which in turn requires a cooling tower.

Intermittent absorption cooling:

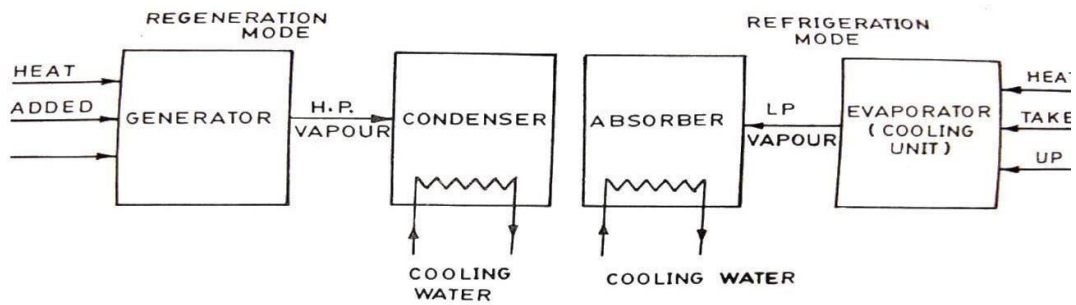

A modified method for absorption cooling which operates intermittently rather than continuously is based on the following principle. In it, the system consists of two vessels which function in two alternative modes. In one mode, one of the vessels is the generator and the other is the condenser of an absorption system. During this phase, heat is supplied to the generator by oil, gas, steam or solar energy. In the alternative mode, the first vessel becomes the absorber and the other the evaporator. During this phase refrigeration occurs. The system operates in the regeneration mode for a few hours and is then changed to the refrigeration mode, and so on. This technique can also be used for food preservation in rural areas, where electric power is not readily available. In the refrigeration mode, heat is supplied to a dilute solution of lithium bromide in water contained in the generator unit. Water vapor at a moderately high pressure passes to the condenser unit and is condensed by cooling water. When sufficient liquid water has collected in the condenser, the heat supply and cooling water are shut off and the refrigeration mode becomes operative. The lithium bromide solution in the absorber unit is cooled so that its vapor pressure is lowered. This causes the water in the evaporator to vaporize, and as a result cooling occurs. The relatively low pressure water vapor is then absorbed by the solution in the absorber unit. After some time, the initial conditions are restored, and the system reverts to the regeneration mode.

The other refrigerant absorbent combinations used in this system are ammonia water ($\text{NH}_3\text{-H}_2\text{O}$) and ammonia-sodium thiocyanate ($\text{NH}_3\text{-NaSCN}$).

SOLAR POWER GENERATION BY THERMAL STORAGE

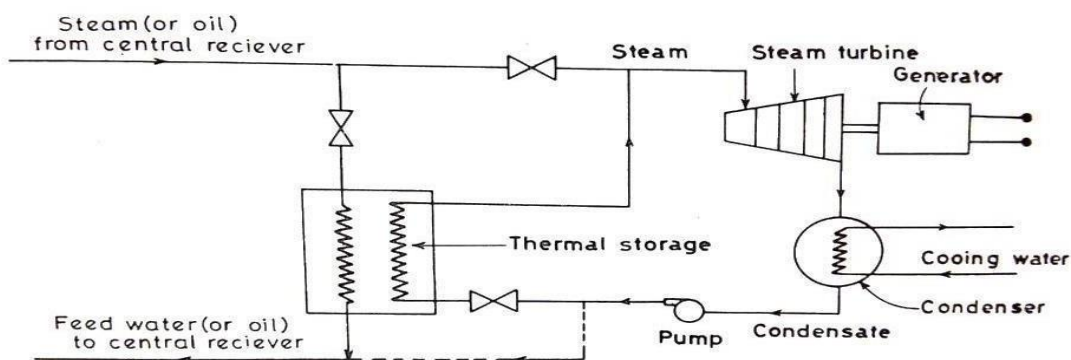

Fig. 5.5.6. Electric power generation using thermal storage.

Solar electric power generation by solar photovoltaic cells:

A PVC is one which converts photons into voltage or light energy to electricity. The materials used for this is silicon which has 4 free valence e^- s in its outermost cell. When the silicon is doped with phosphorous or arsenic having 5 valence e^- s in the outer most cell it forms an 'n-junction' 4 e^- s of phosphorous with 4 e^- s of silicon and one negative charged electron is left out in the 'n-junction'. Similarly the 'p-junction' is formed by doping silicon with boron having 3 valence e^- s in its outermost cell to create positively charged hole which attracts negatively charged electron from n top junction through external load of cell.

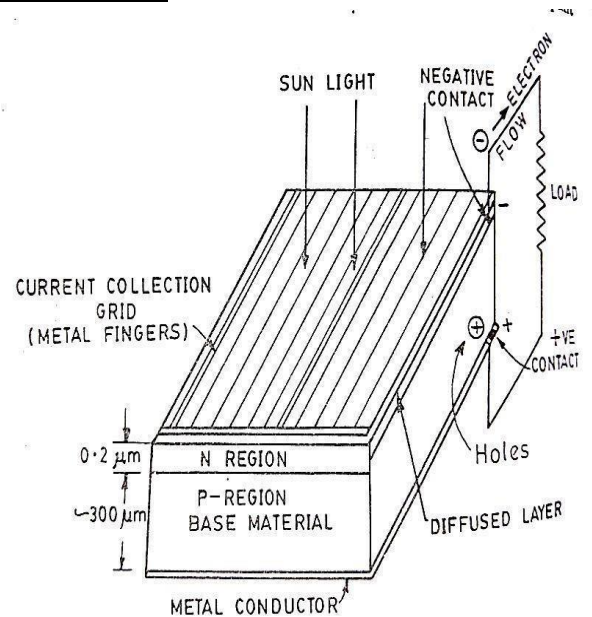

Fig. 5.6.1. Schematic view of a typical solar cell.

SOLAR DISTILLATION:

Potable or fresh water is one of the fundamental necessities of life for a man. Industries and agriculture also require fresh water without which they cannot thrive. Man has been dependent on rivers, lakes and underground water reservoir to fulfill his need of fresh water the use of solar energy for desalting seawater and brackish well water has been demonstrated in several moderate sized pilot plants in the Unites States, Greece, Australia and several other countries. The idea was first applied in 1982.

A simple basin type solar still consists of a shallow blackened basin filled with saline or brackish water to be distilled. The depth of water is kept about 5-10 cm. It is covered with slopy transparent roof. Solar radiation, after passing through the roof is absorbed by the blackened surface of the basin and thus increases the temperature of the water. The evaporated water increases the moisture content, which gets condensed on the cooler underside of the glass. The condensed water slips down the slope and is collected through the condensate channel attached to the glass. The construction is shown in figure above.

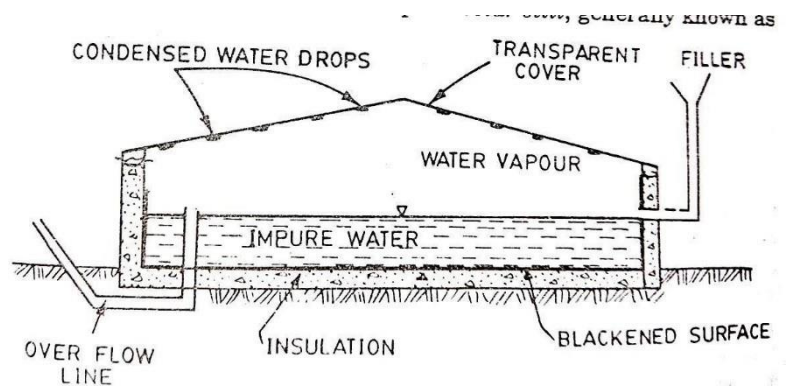

Fig. 5.8.1. Solar Water Still.

SOLAR POND

A solar pond is a mass of shallow water about 1 or 2 meters deep with a large collection area, which acts as a heat trap. It contains dissolved salts to generate a stable density gradient. Part of the incident solar radiation entering the pond surface is absorbed throughout the depth and the remainder which penetrates the pond is absorbed at the black bottom. If the pond were initially filled with fresh water, the lower layers would heat up, expand and rise to the surface. Because of the convective mixing and heat loss at the surface, only a small temperature rise in the pond could be realized. On the other hand, convection can be eliminated by initially creating a sufficiently strong salt concentration gradient. In this case, thermal expansion in the hotter lower layers is insufficient to destabilize the pond. With convection suppressed, the heat is lost from the lower layers only by conduction. Because of the relatively low conductivity, the water acts as an insulator and permits high temperature (over 90°C) to develop in the bottom layers. At the bottom of the pond, a thick durable plastic liner is laid. Materials used for the liner include butyl rubber, black polyethylene and hyperon reinforced with nylon mesh. Salts like magnesium chloride, sodium chloride or sodium nitrate are dissolved in the water, the concentration varying from 20 to 30 percent at the bottom to almost zero at the top.

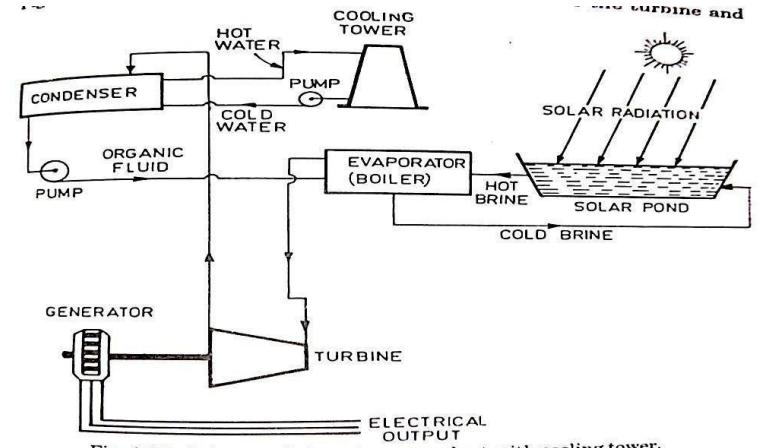

Fig. 4.3.3. Solar pond electric power plant with cooling tower.

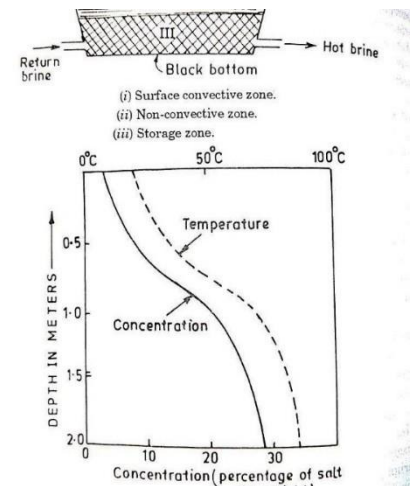

Fig. 4.3.2. Temperature and concentration profile for a typical pond.

Module - 3

INTRODUCTION

HEAT EXCHANGERS

- A heat exchanger is a system used to transfer heat between two or more fluids.
- Heat exchangers are used in both cooling and heating processes.
- The fluids may be separated by a solid wall to prevent mixing or they may be in direct contact.
- They are widely used in space heating, refrigeration, air conditioning, power stations, chemical plants, petrochemical plants, petroleum refineries, natural-gas processing, and sewage treatment.
- The classic example of a heat exchanger is found in an internal combustion engine in which a circulating fluid known as engine coolant flows through radiator coils and air flows past the coils, which cools the coolant and heats the incoming air.
- Another example is the heat sink, which is a passive heat exchanger that transfers the heat generated by an electronic or a mechanical device to a fluid medium, often air or a liquid coolant.

SOLAR THERMAL COLLECTOR

- Solar Thermal Collectors are **special kind of heat exchangers** that **transform solar radiation energy to internal energy of the transport medium.**
- A solar collector is a device for collecting solar radiation and transfer the energy to a fluid passing in contact with it.
- Utilization of solar energy requires solar collectors.
- It is an integral part of any solar thermal system.
- A collector is a device that absorbs the incoming solar radiation, converts it into heat, transfers this heat to the fluid (air, oil or water) flowing through the collector. This is then sent to the hot water or space conditioning equipment or thermal storage tank for use at night or on cloudy days.

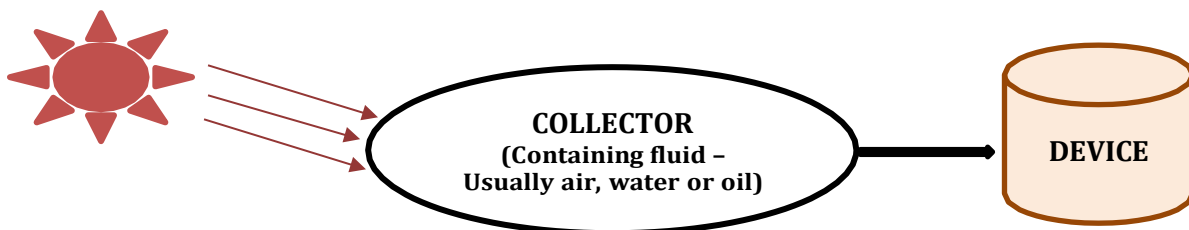

TYPES OF SOLAR THERMAL COLLECTOR

- These are either
 - (a) **Non-Concentrating** – the collector area (that intercepts the radiation) is same as the absorber area (that which absorbs the radiation). In this type, the whole solar panel absorbs light.
 - (b) **Concentrating** – the collector or interceptor area is bigger than the absorber area.

TYPES OF SOLAR THERMAL COLLECTOR

For domestic/industrial water and space heating purposes, solar thermal collectors are classified as:

1. Flat Plate Solar Collectors
2. Evacuated Tube Solar Collectors

FLAT PLATE SOLAR COLLECTORS

- Flat plate collectors were developed by Hottel and Whillier in the 1950s
- The flat-plate solar collectors are the most fundamental and commonly used solar-powered domestic hot water systems where the **temperature demand is low**.
- The idea behind this technology is that the **Sun** heats a **dark flat surface**, which **collects as much energy** as possible, and then the **energy is transferred to water, air, or other fluid for further use**.
- The flat plate collector therefore, is basically a black surface that is placed in a convenient path of the sun.

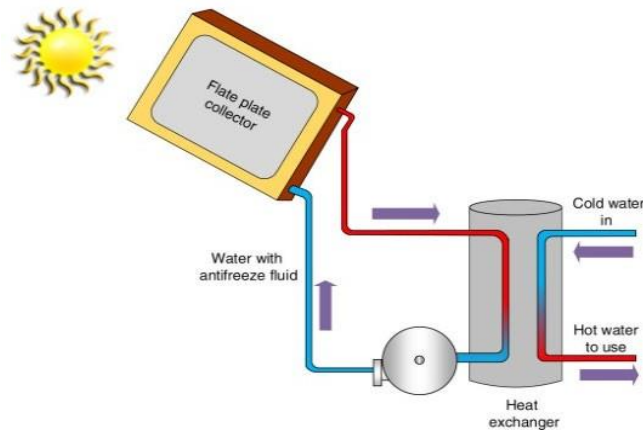

GENERAL DESCRIPTION OF LIQUID FLAT PLATE COLLECTORS

- The basic parts that make up a conventional liquid flat-plate collector are
 - (i) the absorber plates
 - (ii) the tubes fixed to the absorber plate through which the liquid to be heated flows
 - (iii) the transparent cover
 - (iv) the collector box.
- The main advantage of a flat-plate collector is that it utilises both the beam and diffuse components of the solar radiation.
- In addition, because of its simple stationary design, it requires little maintenance.
- Its principal disadvantage is that because of the absence of optical concentration, the area from which heat is lost is large.
- As a result, the collection efficiency is generally low.
- The liquid heated is generally water. However, sometimes mixtures of water and ethylene glycol are used if ambient temperatures below 0°C are likely to be encountered.
- The absorber plate is usually made from a thin metal sheet ranging in thickness from 0.2 to 0.7 mm, while the tubes, which are also of metal, range in diameter from 1 to 1.5 cm. They are soldered, brazed or pressure bonded to the bottom of the absorber plate with the pitch ranging from 5 to 12 cm.
- In some designs, the tubes are bonded to the top or are in-line and integral with the absorber plate.
- The metal most commonly used, both for the absorber plate and the tubes, is copper.
- The header pipes, which lead the liquid in and out of the collector and distribute it to the tubes, are made of the same metal as the tubes and have slightly larger diameters (2 to 2.5 cm).
- The cover should be made of a material which is highly transparent to incoming solar radiation and at the same time, opaque to long wavelength re-radiation emitted by the absorber plate.
- Glass with a low ferric oxide content satisfies these requirements.
- Toughened glass of 4- or 5-mm thickness is the most favoured material.

- This type of glass is able to withstand thermal shock as well as the impact of objects which may fall on the collector face.
- The usual practice is to have one cover with a spacing ranging from 1.5 to 3 cm between the cover and the absorber plate.
- The bottom and sides are usually insulated by mineral wool, rock wool or glass wool with a covering of aluminium foil and has a thickness ranging from 2.5 to 8 cm.
- The whole assembly is contained within a box which is tilted at a suitable angle.
- The collector box is usually made of aluminium with an epoxy coating on the outside for protection.
- The face areas of most commercially available collectors are around 2 m² with the length (along the sloping direction) being usually larger than the width.
- In the last few years, the use of plastic materials for the absorber plate, the tubes as well as the cover has increased.
- This is particularly true for applications involving lower temperatures up to 600 or 700C.
- Initially plastics were not used because they degraded on exposure to sunlight.
- They also have low thermal conductivities and high coefficients of expansion as compared to metals.
- However, advances in polymer technology have resulted in the development of suitable plastic materials which can withstand long exposures to sunlight.
- Plastics have the advantages of being light in weight and easy to manufacture.
- They also cost less and require less energy input for their manufacture than metals like copper and aluminium.
- However, it has to be remembered that they generally originate from fossil fuels.
- The present rate of production of liquid flat-plate collectors in the world, as well as in India, is low.
- However, it is increasing rapidly.
- About 1000000 m of collector area has been installed in India up to 2004, the typical cost of a good quality collector being in the range of Rs 4000 to 4500 per m².

SELECTIVE SURFACES

- Absorber plate surfaces which exhibit the characteristics of a **high value of absorptivity** for incoming solar radiation and a **low value of emissivity** for outgoing re-radiation are called **Selective Surfaces**.
- Such surfaces are **desirable** because they **maximize the absorption of solar energy** and **minimize the emission of the radiative loss**.
- They yield higher collector efficiencies than those that are obtained when the absorptivity and emissivity are equal.
- A number of surfaces having characteristics approaching those of an ideal surface have been synthesised and a few have been commercialized.
- In most of these surfaces, the **selectivity is achieved by having a polished and cleaned metal base and depositing on it a thin layer which is transparent to large wavelengths, but highly absorbing for small wavelength solar radiation**.
- Surface layers of copper oxide were among the first selective surfaces to be suitable from a practical point of view.
- The copper oxide layer was formed by chemical conversion, by treating a cleaned and polished copper plate in a hot solution of sodium hydroxide and sodium chlorite for a specified time.

- Values of absorptivity (α) and emissivity (ϵ) obtained for this surface were 0.89 and 0.17 respectively at about 100°C, α being the average value of α_{λ} over the solar radiation wavelength range and ϵ_p being the average value of ϵ_{λ} for large wavelength radiation.
- Currently, most of the commercialized selective surface coatings are metal dielectric composite coatings, known as Cermets.
- They consist of fine metal particles in a dielectric or ceramic matrix, or a porous oxide impregnated with metal.
- **Thin films of these composites are transparent in the high wavelength region and strongly absorbing in the solar wavelength region.**
- Thus, they form a selective surface when deposited on a highly reflective metal surface.
- The nickel-black coating was initially developed in Israel 40 years ago.
- The process involved the **cleaning of a metal sheet and subsequent electroplating by immersion of the sheet as the cathode in an aqueous electrolytic bath of nickel sulphate, zinc sulphate, ammonium sulphate, ammonium thiocyanate and citric acid.**
- One of the most successful selective surfaces developed so far is '**Black Chrome**'.
- It consists of a **Cr particle/Cr₂O₃ composite electroplated on a nickel-plated copper, copper or stainless-steel base.**
- The commercial product is available from MTI in USA, Chrome Coat in Denmark and Energie Solaire in Switzerland.
- Values of α ranging from 0.95 to 0.97 and ϵ from 0.09 to 0.15 have been noted.
- In India, 'black chrome' coatings on copper are made by a few manufacturers.
- Values of α ranging from 0.94 to 0.97 and ϵ from 0.14 to 0.20.

BASIC ENERGY – BALANCE EQUATION

- Energy balance is simply the relationship between energy input and energy output.
- In thermal systems, this is defined as: “A fundamental concept for thermal analysis of any thermal system is the conservation of energy, which can be analysed through energy balance calculation under steady state conditions. In steady state, the useful energy output of the collector is the difference between the absorbed solar radiation and the total thermal losses from the collector.”

$$\text{Useful energy} = \text{Absorbed solar energy} - \text{Thermal losses}$$

- An energy balance on the absorber plate yields the following equation;

$$q_u = A_p S - q_l$$

Where,

q_u = useful heat gain, i.e., the rate of heat transfer to the working fluid,

S = incident solar flux absorbed in the absorber plate,

A_p = area of the absorber plate,

q_l = rate at which heat is lost by convection and re-radiation from the top, and by conduction and convection from the bottom and sides.

- The flux incident on the top cover plate is given by:

$$I_T = I_b r_b + I_d r_d + (I_b + I_d) r_r$$

- Each of the terms in the above equation is multiplied by a term called the **transmissivity-absorptivity product** (r_a) in order to determine the flux S absorbed in the absorber plate.
- Thus,

$$I_T = I_b r_b (r_a)_b + \{I_d r_d + (I_b + I_d) r_r\} (r_a)_d$$

Where,

τ = transmissivity of the glass cover system, the ratio of the solar radiation coming through after reflection at the glass-air interfaces and absorption in the glass to the radiation incident on the glass cover system,

α = absorptivity of the absorber plate,

$(\tau \alpha)_b$ = transmissivity-absorptivity product for beam radiation falling on the collector

$(\tau \alpha)_d$ = transmissivity-absorptivity product for diffuse radiation falling on the collector.

- The **instantaneous collection efficiency** is given by

$$\eta = \frac{\text{Useful heat gain}}{\text{Radiation incident on the collector}} = \frac{q_u}{A_c I_T}$$

Where,

A_c = is the collector gross area (the area of the topmost cover including the frame). **A_c is usually 15 to 20 per cent more than A_p .**

STAGNATION TEMPERATURE

- If the liquid flow rate through the collector is stopped, there is no useful heat gain and the efficiency is zero.
- In this case, the absorber plate attains a temperature such that $A_p S = q_l$.
- This temperature is the highest that the absorber plate can attain and is sometimes referred to as the **Stagnation Temperature**.
- Knowledge of the stagnation temperature is useful as an indicator for comparing different collector designs.
- It also helps in choosing proper materials for construction of the collector.

TRANSMISSIVITY OF THE COVER SYSTEM

- The transmissivity of the cover system of a collector (r) can be obtained with adequate accuracy by considering reflection-refraction and absorption separately, and is given by the product form

$$r = r_r r_a$$

Where,

r_r = transmissivity obtained by considering only reflection and refraction

r_a = transmissivity obtained by considering only absorption.

Transmissivity Based on Reflection-Refraction (r_r)

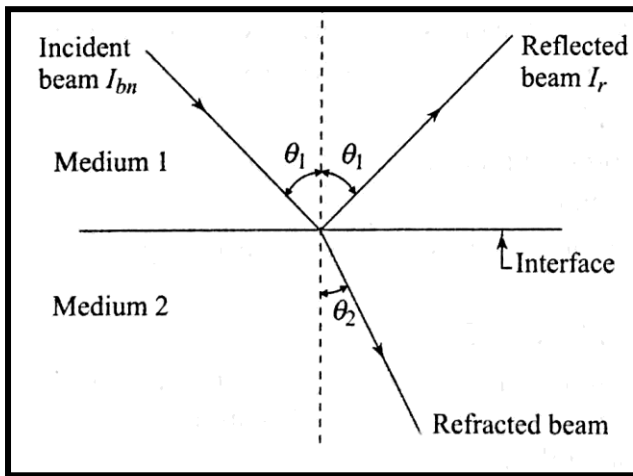

Fig. Reflection and Refraction at the interface of two media

- When a beam of light of intensity I_{bn} travelling through a transparent medium 1, strikes the interface separating it from another transparent medium 2, it is reflected and refracted as shown the figure.
- The reflected beam has a **reduced intensity I_r** and has a **direction such that the angle of reflection is equal to the angle of incidence.**
- On the other hand, the directions of the incident and refracted beams are related to each other by Snell's law which states that:

$$\frac{\sin \theta_1}{\sin \theta_2} = \frac{n_2}{n_1}$$

Where,

θ_1 = angle of incidence

θ_2 = angle of refraction

n_1, n_2 = refractive indices of the two media

- The reflectivity $\rho (= I_r/I_{bn})$ is related to the angles of incidence and refraction by the equations:

$$\rho = \frac{1}{2} (\rho_I + \rho_{II})$$

$$\rho_I = \frac{\sin^2(\theta_2 - \theta_1)}{\sin^2(\theta_2 + \theta_1)}$$

$$\rho_{II} = \frac{\tan^2(\theta_2 - \theta_1)}{\tan^2(\theta_2 + \theta_1)}$$

Where, ρ_I and ρ_{II} are the two components of polarisation.

- For the special case of **Normal Incidence ($\theta_{11} = 0^\circ$)**, we have

$$\rho = \rho_{II} = \frac{n_1 - n_2}{n_1 + n_2}$$

- The transmissivity τ_r is given by an expression similar to that for ρ

$$\therefore \rho = \frac{1}{2} (r_{rI} + r_{rII})$$

Where,

r_{rI} and r_{rII} are the transmissivities of the two components of polarisation.

- Consider one of the components of polarisation of a beam Incident on a single cover.
- Because of the fact that there are two interfaces, multiple reflections and refractions will occur as shown in the figure below:

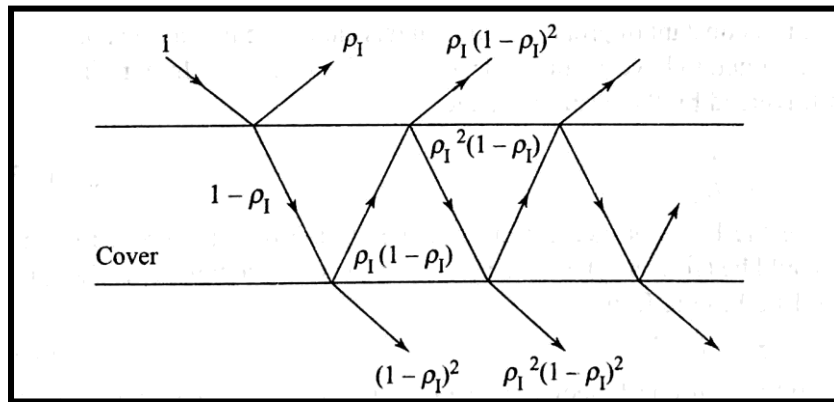

Fig.: Ray diagram showing transmission through a single cover considering reflection - refraction

$$\begin{aligned} \therefore r_{rI} &= (1 - \rho_I)^2 + \rho_I^2(1 - \rho_I)^2 + \rho_I^4(1 - \rho_I)^2 + \dots \\ &= (1 - \rho_I)^2 (1 + \rho_I^2 + \rho_I^4 + \dots) = \frac{(1 - \rho_I)^2}{(1 - \rho_I^2)} = \frac{1 - \rho_I}{1 + \rho_I} \end{aligned}$$

Similarly,

$$r_{rII} = \frac{1 - \rho_{II}}{1 + \rho_{II}}$$

• For a system of M no. of covers,

$$\begin{aligned} r_{rI} &= \frac{1 - \rho_I}{1 + (2M - 1)\rho_I} \\ r_{rII} &= \frac{1 - \rho_{II}}{1 + (2M - 1)\rho_{II}} \end{aligned}$$

Transmissivity based on absorption (r_a)

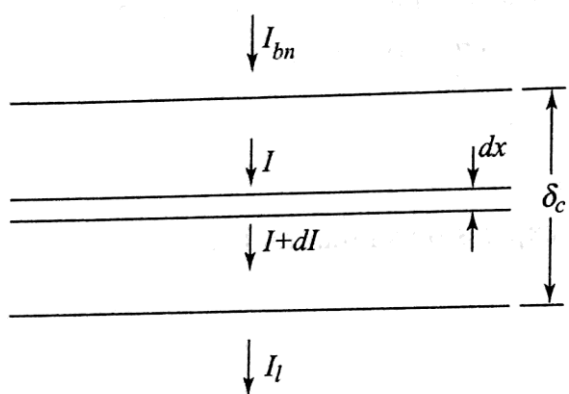

Fig.: Absorption in a transparent cover

- The transmissivity based on absorption can be obtained by assuming that the attenuation (decrease) due to absorption is proportional to the local intensity (Bouger's law).
- Consider a beam of intensity I_{bn} incident normally on a transparent cover of thickness δ_c and emerging with an intensity I_l as shown in the figure.

• From Bouger's law,

$$dl = -KIdx$$

Where, K is a constant of proportionality and is called the **Extinction Coefficient**. It will be assumed to have a value independent of wavelength.

• Integrating over the length traversed by the beam, we get,

$$r_{\alpha} = \frac{I_l}{I_{bn}} = e^{-K\delta\delta_c}$$

- In case the beam is incident at an angle θ_1 , the path traversed through the cover would be $\frac{\delta\delta_c}{\cos\theta_2}$, where θ_2 is the angle of refraction.
- Then r_{α} gets modified to the form $\cos\theta_2$

$$r_a = e^{-K\delta\delta_c / \cos\theta_2}$$

- The extinction coefficient K is a property of the cover material.
- Its value varies from about 4 to 25 m^{-1} for different qualities of glass.
- A low value is obviously desirable.
- If there are M covers, the exponent in these equations would be multiplied by M .

Transmissivity for Diffuse Radiation

- The preceding considerations apply only to beam radiation.
- Calculation of the transmissivity of a cover system when diffuse radiation is incident on it is a little difficult as the radiation comes from many directions.
- The usual practice is to assume that the diffuse radiation is equivalent to beam radiation coming at an angle of incidence of 60° .
- This angle is arrived at by considering the variation of r and by assuming that the amount of diffuse radiation coming from all directions is the same.

TRANSMISSIVITY – ABSORPTIVITY PRODUCT

- The transmissivity-absorptivity product is defined as the ratio of the flux absorbed in the absorber plate to the flux incident on the cover system, and is denoted by the symbol $(r\alpha)$, an appropriate subscript (b or d) being added to indicate the type of incident radiation.

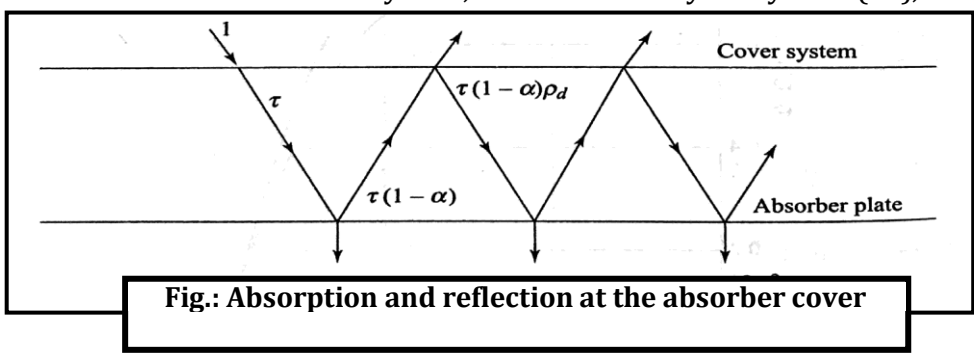

being added to indicate the type of incident radiation.

- From the fraction of r transmitted through the cover system, a part is absorbed and a part reflected diffusely.

- From the reflected part, a portion is transmitted through the cover system and a portion is reflected back to the absorber plate.
- The process of absorption and reflection at the absorber plate surface as shown in the figure below goes on indefinitely, the quantities involved become smaller and smaller.
- Therefore, the net fraction absorbed $(r\alpha)$

$$= [1 + (1 - \alpha)\rho_d + (1 - \alpha)^2\rho_d^2 + \dots]$$

$$= \frac{r\alpha}{1 - (1 - \alpha)\rho_d}$$

- The symbol ρ_d represents the diffuse reflectivity of the cover system.

- It can be found by determining the value $(1 - r_r)$ for the cover system for an incidence angle of 60° .

THE OVERALL LOSS COEFFICIENT

- Heat lost from the collector in terms of an overall loss coefficient is defined by the equation

$$q_{ql} = U_l A_p (T_{pm} - T_a)$$

Where,

U_l = overall loss coefficient

A_p = area of the absorber

T_{pm} = average temperature of the absorber plate

T_a = temperature of the surrounding air (assumed to be the same on all sides

of the collector).

- The heat lost from the collector is the sum of the heat lost from the top, the bottom and the sides. Thus,

$$q_l = q_t + q_b + q_s$$

Where,

q_t = rate at which heat is lost from the top,

q_b = rate at which heat is lost from the bottom

q_s = rate at which heat is lost from the sides.

- Each of these losses is also expressed in terms of coefficients called the (a) **top loss coefficient**, (b) the **bottom loss coefficient** and (c) the **side loss coefficient** and defined by the equations:

$$q_t = U_t A_p (T_{pm} - T_a)$$

$$q_b = U_b A_p (T_{pm} - T_a)$$

$$q_s = U_s A_p (T_{pm} - T_a)$$

$$U_l = U_t + U_b + U_s$$

- As thermal resistances, these losses can be represented as in the circuit diagram shown below:

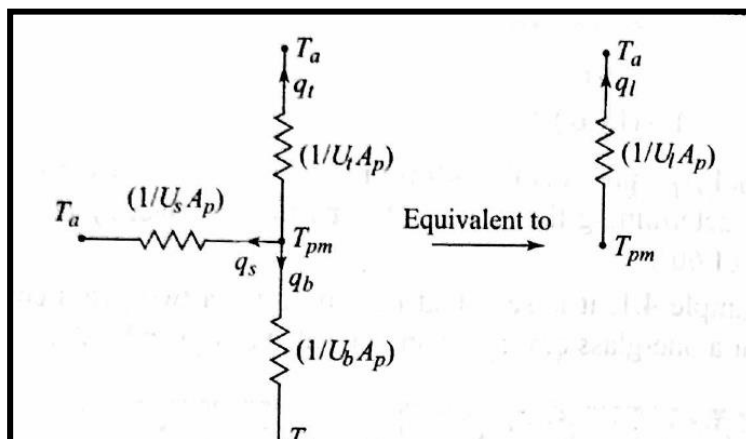

(a) **Top loss coefficient**

- The top loss

Fig.: Thermal Resistance Network showing collector losses

coefficient (U_t) is

evaluated by considering convection and re-radiation losses from the absorber plate in the **upward direction**.

- For purposes of calculation, the following assumptions are made:
 - **The transparent covers and the absorber plate constitute a system of infinite parallel surfaces and that the flow of heat is one dimensional and steady.**
 - **The temperature drop across the thickness of the covers is negligible and that the interaction between the incoming solar radiation absorbed by the covers and the outgoing loss may be neglected.**
 - **The outgoing radiation is of large wavelengths for which the transparent cover is assumed to be opaque.**

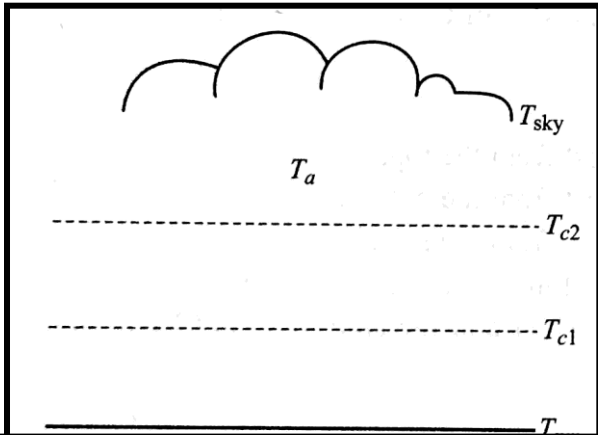

- A schematic diagram for a two-cover system is shown in the figure.
- In a steady state, the heat transferred by convection and radiation between (i) the absorber plate and the first cover, (ii) the first cover and the second cover, and (iii) the second cover and the surroundings must be equal.

Fig.: Calculation of the Top Loss Coefficient

$$\begin{aligned}
 \frac{q_t}{A_p} &= h_{p-c1} (T_{pm} - T_{c1}) + \frac{\sigma(T_{pm}^{44} - T_{c1}^{44})}{\frac{1}{\epsilon_p} + \frac{1}{\epsilon_c} - 1} \\
 &= h_{c1-c2} (T_{c1} - T_{c2}) + \frac{\sigma(T_{c1}^{44} - T_{c2}^{44})}{\frac{1}{\epsilon_c} + \frac{1}{\epsilon_c} - 1} \\
 &= h_{ww} (T_{c2} - T_a) + \sigma \epsilon_c (T_{c2}^{44} - T_{sky}^{44})
 \end{aligned}$$

Where,

h_{p-c1} = convective heat transfer coefficient between the absorber plate and the first cover,

h_{c1-c2} = convective heat transfer coefficient between the first and second covers,

h_{ww} = convective heat transfer coefficient between the topmost cover (in this case the second) and the surrounding air,

T_{c1}, T_{c2} = temperatures attained by the two covers,

T_{sky} = effective temperature of the sky with which the radiative exchange takes place = $T_a - 6$

ϵ_p = emissivity of the absorber plate for long wavelength radiation, and

ϵ_c = emissivity of the covers for long wavelength radiation.

- The above equations form a set of three non-linear equations.

- These need to be solved for 3 unknowns q_t , T_{c1} and T_{c2} .
- In order to solve these, some of correlations for calculating heat transfer coefficients - h_{p-c1} , h_{c1-c2} and h_{ww} and the sky temperature T_{sky} are:

- Heat transfer Coefficient at the Top Cover
- Sky Temperature.

(b) Bottom loss co-efficient

- The bottom loss coefficient (U_b) is evaluated by considering conduction and convection losses from the absorber plate in the **downward direction** through the bottom of the collector.
- It is assumed that the **flow of heat is one-dimensional and steady**.
- In most cases, the thickness of insulation provided is such that the thermal resistance associated with conduction dominates.
- Thus, neglecting the convective resistances, we have

$$U_b = \frac{k_i}{\delta_b}$$

Where,

k_i = thermal conductivity of the insulation

δ_b = thickness of the insulation

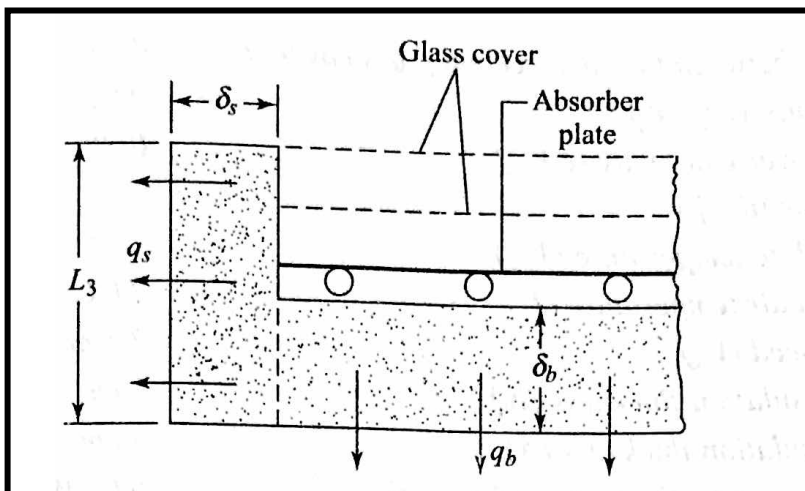

Fig.: Bottom and Side Losses from a flat plate collector

$$2(L_1 + L_2)L_3.$$

- The temperature drops across which the heat flow occurs varies from $(T_{pm} - T_a)$ at the absorber plate level to zero both at the top and bottom.
- Assuming, therefore, that the average temperature drops across the side insulation is $(T_{pm} - T_a)/2$ and that the thickness of this insulation is δ_s , we have

$$q_s = 2L_3(L_1 + L_2)k_i \frac{(T_{pm} - T_a)}{2\delta_s}$$

$$\therefore U_s = \frac{(L_{11} + L_{12})L_{33}k_{ii}}{L_{14} \delta_s}$$

TEMPERATURE DIFFERENCE BETWEEN THE COLLECTOR TUBES

- The heat lost from the collector can be calculated, if the average plate temperature is known.
- However, this temperature is generally not known.

(c) Side loss co-efficient

- As in the case of the bottom loss coefficient, it is assumed that the **conduction resistance dominates** and that the **flow of heat is one-dimensional and steady**.
- The one-dimensional approximation can be justified on the grounds that the side loss coefficient is always much smaller than the top loss coefficient.
- If the dimensions of the absorber plate are $L_1 \times L_2$ the height of the collector casing is L_3 , then the area across which heat flows sideways is

- Therefore, it is necessary to consider the flow of heat in the absorber plate and across the fluid tubes to the fluid so that the values of T_{pm} can be related to the value of the inlet fluid temperature, which is a known quantity.
- A number of one-dimensional analyses are to be conducted.
- First, the one-dimensional flow of heat in the absorber plate in a direction at right angles to the direction of fluid flow is considered.
- This will be followed by a consideration of the heat flow from the plate to the fluid across the tube wall.
- Finally, the one-dimensional flow of fluid inside the tubes will be analysed.
- Consider a collector having an absorber plate of length L_1 and width L_2 .
- Assume that there are N fluid tubes and that the pitch of the tubes is $W (= L_2/N)$
- Let D_i and D_o be the inside and outside diameters of the tubes.
- Consider a section of the absorber plate with two adjacent fluid tubes.
- The temperature in the plate (T_p) will vary in the x -direction in the manner as shown in the figure.
- It will be assumed that the same distribution exists between any tubes.
- **Above the fluid tubes, the temperature will be constant, while in between the tubes, temperature will pass through a maximum.**
- Taking a slice dy along the flow direction and neglecting heat conduction in the plate in that direction, we can write an energy balance for an element $dx \times dy$ of the plate.

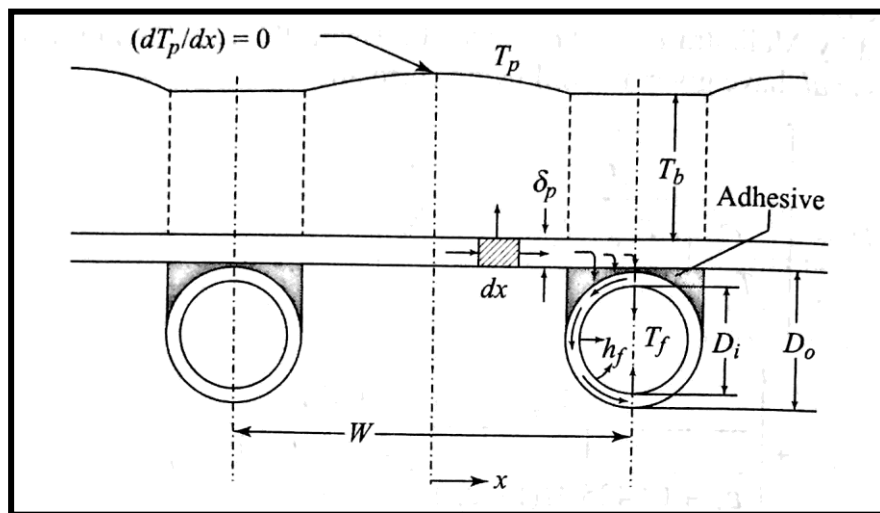

(Net heat conducted into the element) + (Incident Energy absorbed)
 = Heat lost from the element

$$k_p \delta_p \frac{d^2 T_p}{dx^2} dy + S dx dy = U_l dx dy (T_p - T_a)$$

$$\frac{d^2 T_p}{dx^2} = \frac{U_l}{k_p \delta_p} T_p - T_a - \frac{S}{U_l}$$

- Applying the following boundary conditions on the above equation,

$$x = 0, \frac{dT_p}{dx} = 0 \text{ and } x = \frac{W - D_o}{2}, T_p = T_{po}$$

- This gives,

$$\frac{T_p - U_l + \frac{S}{U_l}}{T_{po} - T_a + U_l} = \frac{m(W - D_o)}{2}$$

where $m = (U_l/k_p \delta_p)^{1/2}$.

- The temperature distribution is similar to that of temperature distribution in a fin.
- The rate at which energy is conducted through the plate to one fluid tube from both sides

$$= -2k_p \delta_p \left(\frac{dT_p}{dx} \right)_{x=(W-D_o)/2} dy$$

$$= 2 \left(\frac{k_p \delta_p}{U_l} \right)^{1/2} [S - U_l(T_{po} - T_a)] \tanh \left(\frac{m(W - D_o)}{2} \right) dy$$

- The rate at which energy is absorbed just above the tube is

$$= D_o [S - U_l(T_{po} - T_a)] dy$$

- Thus, the useful energy gain for all the N tubes of the collector over a length dy is given by

$$dq_u = N[S - U_l(T_{po} - T_a)] \times \left[2 \left(\frac{k_p \delta_p}{U_l} \right)^{1/2} \tanh \frac{m(W - D_o)}{2} + D_o \right] dy$$

- The above equation can also be written in a simpler manner by introducing the concept of plate effectiveness ϕ , which is defined as the ratio of the heat conducted through the plate to the fluid tube, to the heat which would have been conducted if the thermal conductivity of the plate material was infinite.

$$\phi = \frac{\tanh [m(W - D_o)/2]}{[m(W - D_o)/2]}$$

$$\frac{1}{N} \left(\frac{dq_u}{dy} \right) = [S - U_l(T_{po} - T_a)] [\phi(W - D_o) + D_o]$$

- Consider the flow of heat from the plate to the fluid.
- The three thermal resistances in the path are due to the adhesive used for attaching the tubes to the absorber plate, the tube wall and the heat transfer coefficient at the inner surface of the tube. Assuming the thermal resistance of the tube wall to be negligible,

$$\frac{1}{N} \frac{dq_u}{dy} = \frac{(T_{po} - T_{ff})}{\frac{\delta_a}{k_a D_a} + \frac{1}{\pi D_i h_f}}$$

Where,

δ_a = average thickness of the adhesive,

k_a = thermal conductivity of the adhesive material

T_f = local fluid temperature, and

h_f = heat transfer coefficient on the inside surface of the tube.

COLLECTOR HEAT-REMOVAL FACTOR

- The final one-dimensional analysis will be performed along the direction of fluid flow with the objective of determining the variation of fluid temperature.
- This analysis will help in linking the useful heat gain rate with the fluid inlet temperature.
- Consider a length dy as a control volume of one tube.
- Applying first law of thermodynamics.

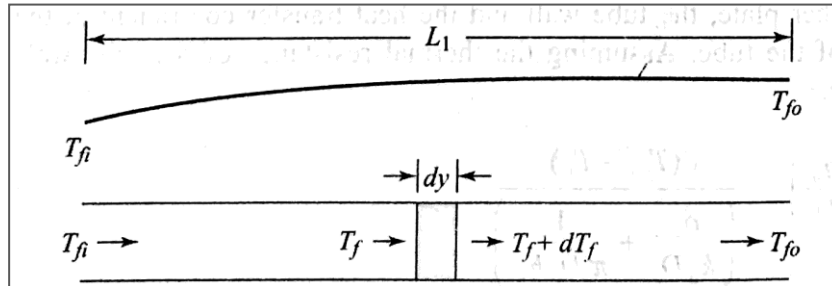

$$\frac{dT_f}{dy} = \frac{WF' U_l}{(\dot{m}/N)C_p} \left[\left(\frac{S}{U_l} + T_a \right) - T_f \right]$$

EFFECT OF VARIOUS PARAMETERS ON THE COLLECTOR PERFORMANCE

- A large number of parameters influence the performance of a liquid flat-plate collector.
- These parameters could be classified as **design parameters, Operational parameters, meteorological parameters and environmental parameters.**

Collector Orientation

- Flat-plate collectors are normally fixed in one position and do not track the sun.
- Because of this factor, the amount of tilt or the orientation of the plate is an important factor.
- Assuming that extra-terrestrial insolation was falling on the collector plate, calculations were made.
- They calculated the annual insolation per unit area by integrating the expression for the flux on a tilted surface first over the day length and then summing up over the days of the year.
- Taking $\gamma = 0^\circ$, so that the daily insolation is maximized, the following expression is obtained:

$$Q_{opt} = \int_{ii=11}^{1122} \int_{ii=11}^{1122} \left(\frac{S}{U_l} + T_a \right) - T_f$$

Sele

- The effect of a selective surface on the performance of a collector can be best illustrated by taking specific situations.
- A collector's performance without a selective surface ($\alpha = \epsilon = 0.94$) and with a selective surface ($\alpha = 0.95$, $\epsilon = 0.085$) is calculated.
- The calculations are carried out in a manner similar to that adopted earlier and the results obtained are indicated in the table below:

$T_{fo}(K)$	344.1	341.1	344.6
$\eta_{ii}(\%)$	43.6	31.5	45.4

Table: Effect of a selective surface on performance of collector

- It is seen from the above table that with a non-selective absorber plate, the top loss coefficient is 7.26 W/m²-K and the efficiency is 31.5 per cent.
- The top loss coefficient increases by 3.14 W/m²-K, while the efficiency decreases by 12.1%.
- Thus, significant differences are observed.
- With the other selective surface, in which the value of α is marginally higher and that of ϵ_p is less, it is observed that the value of U_t decreases and the efficiency increases a little compared to the first selective surface.

Number of Covers

- The effect of the number of covers on the performance of a collector can be studied considering a sample collector with a selective surface having with $\alpha = 0.94$ and $\epsilon = 0.14$ and a non-selective surface with $\alpha = \epsilon = 0.94$.
- Calculations are carried out for 1, 2 and 3 covers

	Number of covers (Effect of selective Surface)		
	1	2	3
$(ra)_b$	0.8041	0.6892	0.5932
$(ra)_d$	0.7284	0.6008	0.5114
$U_t(WW/m^2 - K)$	4.12	2.68	1.99
$\eta_{ii}(\%)$	43.6(highest efficiency)	41.0	36.6

	Number of covers (Effect of non-selective surface)		
	1	2	3
$(ra)_b$	0.8041	0.6892	0.5932
$(ra)_d$	0.7284	0.6008	0.5114
$U_t(WW/m^2 - K)$	7.26	4.04	2.75
$\eta_{ii}(\%)$	31.5	35.3	33.4

- It can be observed from the above tables that, when the absorber plate is **SELECTIVE**:
 - the **highest value of efficiency** is obtained with **one cover**. As the number of covers keep increasing, the efficiency keeps decreasing.
- When the absorber plate is **NON-SELECTIVE**:
 - the **efficiency increases when the number of plates is increased from 1 to 2 but then starts to decrease with further addition of plates**.
- It can hence be concluded that, it is optimum to use **only one cover if the absorber plate is selective and two covers if the absorber plate is non-selective**.

Fluid Inlet Temperature

- The fluid inlet temperature is an operational parameter which strongly influences the performance of a flat-plate collector. The effect is best illustrated by again carrying out calculations for the case similar to the other factors.
- Results are obtained with fluid inlet temperature varying from 30^o to 90^oC, while the values of the other parameters are held constant.

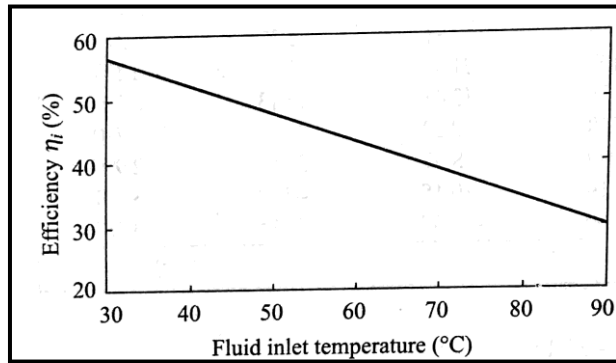

fig.: Variation of efficiency of a collector with fluid inlet temperature

- It is observed that efficiency of the collector reduces as the temperature at inlet increases.
- This is because of the higher temperature level at which the collector as a whole operates when the fluid inlet temperature increases.
- Because of this, the top loss coefficient as well as the temperature difference with the surroundings increases, the heat lost increases and the useful heat gain decreases.

Effect of Dust

- The preceding calculations for the covers of the collector have been done under the assumption that the top cover is clean and has no dust accumulated on it.
- This assumption is acceptable only if the cover is continuously cleaned.
- However, in any practical situation, this is not possible.
- Cleaning is generally done once every few days.
- For this reason, it is recommended that the incident flux be multiplied by a correction factor which accounts for the reduction in intensity because of the accumulation of dust.
- The correction factor is the ratio of the normal transmissivity of a dust-laden cover to the normal transmissivity of a clean cover.
- There is, however, considerable difficulty in assigning a value to the correction factor in a specific situation because of its dependence on a number of parameters.
- The value depends obviously on the **location of the collector and the time of the year, the material of the cover (glass or plastic), the tilt of the collector and the frequency of cleaning.**

PHOTOVOLTAIC CONVERSION

- The devices used in photovoltaic conversion are called **Solar Cells**.
- When solar radiation falls on these devices, it is converted directly into dc electricity.
- The principal advantages associated with solar cells are that they have no moving parts, require little maintenance, and work quite satisfactorily with beam or diffuse radiation.
- Also, they are readily adapted for varying power requirements because a cell is like a **'building block'**.
- The main factors limiting their use are that they are still rather costly and that there is very little economy associated with the magnitude of power generated in an installation.
- However, significant developments have taken place in the last few years.

- As a result of these developments, solar cells are now being used extensively in many consumer products and appliances, and it is possible that in the future they may become one of the important sources of power for providing small amounts of electrical energy for localized use, particularly in remote locations
- Various materials have been used and many types of solar cells have been developed.
- However, more than 90 per cent of the current production of solar cells is from single crystal and multicrystalline silicon only.

PRINCIPLE OF WORKING

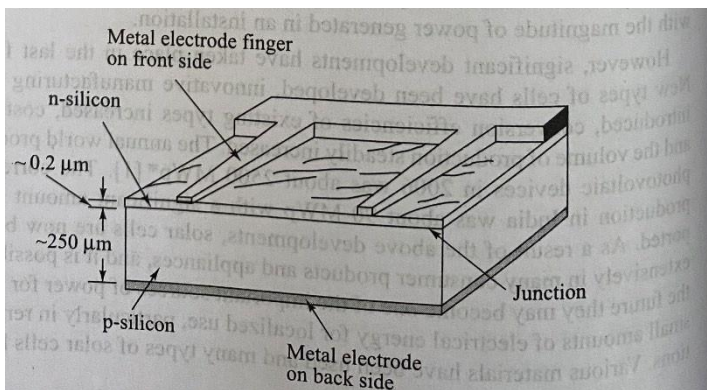

- The first solar cells were made in the fifties from single crystal silicon.
- Even today silicon is the material generally used for making most cells.
- Single crystal silicon cells are thin wafers about 250 in thickness, sliced from a single crystal of p-type doped silicon.
- A shallow junction is formed at one end by diffusion of the n-type impurity.

- Metal contacts are attached to the front and back side of the cell.
- On the front side, the contact is in the form of a metal grid with fingers which permits the sunlight to go through, while on the back side, the contact completely covers the surface.
- Generally, for the front contacts, screen printing of a paste consisting of 70% silver, an organic binder and sintered glass is done.
- For the back contact, a paste containing aluminium is screen printed.
- The cell is placed in a furnace at a temperature of about 600⁰ to 700⁰C so that the metals in the paste diffuse both at the front as well as on the back to make contact with the silicon.
- An anti-reflection coating of silicon nitride or titanium dioxide, having a thickness of about 0.1 gm is applied on the top surface to complete the cell.
- The cells are encapsulated in a thin transparent material in order to protect them from the environment and support them in the module: A number of modules are interconnected to form an array.
- The cells are rectangular in shape, resulting in compact modules.

APPLICATIONS

1. **Solar Farms** - Many acres of PV panels can provide utility-scale power—from tens of megawatts to more than a gigawatt of electricity.
2. **Remote Locations** - It is not always cost-effective, convenient, or even possible to extend power lines to locations where electricity is needed.
3. **Stand-Alone Power** - In urban or remote areas, PV can power stand-alone devices, tools, and meters.
4. **Power in Space** - From the beginning, PV has been a primary power source for Earth-orbiting satellites.
5. **Building-Related Needs** - In buildings, PV panels mounted on roofs or ground can supply electricity.
6. **Military Uses** - Lightweight, flexible thin-film PV can serve applications in which portability or ruggedness are critical.
7. **Transportation** - PV can provide auxiliary power for vehicles such as cars and boats.

MODULE 4

WIND ENERGY

Wind is caused by the uneven heating of the atmosphere by the sun, variations in the earth's surface, and rotation of the earth. Thus the wind energy is a form of solar energy

Wind is the moving air and is caused by the differences in air pressure in our atmosphere. Mountains, bodies of water, and vegetation all influence wind flow patterns

Wind energy (or wind power) describes the process by which wind is used to generate electricity

Wind turbines convert the kinetic energy in the wind into mechanical power by rotating propeller like blades.

A generator can convert mechanical power into electricity i.e. by rotating the propeller blades around a rotor.

Mechanical power can also be utilized directly for specific tasks such as pumping water.

PROPERTIES OF WIND

- Wind is non-conventional energy source
- Wind is due to differences in air pressure in the atmosphere
- Wind at high pressure tends to move to areas at low air pressure, greater the pressure difference faster will be the flow of air
- In meteorology, winds are often referred to according to their strength, and the direction from which the wind is blowing.
- Wind strength can vary from light breeze to hurricane force
- The wind is also a critical means of transportation for seeds, insects, and birds, which can travel on wind currents for thousands of miles.
- Wind is characterized by two parameters. They are wind speed and wind direction. Wind speed indicates the speed of air movement from one point to another measured through a device called “anemometer” and the wind direction indicated the direction at which air is moving measured through a device “wind vane” attached to a direction indicator.

AVAILABILITY OF WIND ENERGY IN INDIA

The total installed capacity of wind power in India as on March 2017 is around 32 GW. Wind power generation capacity in India has significantly increased in recent years. As of 28 February 2021, the total installed wind power capacity is 38.789 GW, the fourth largest installed wind power capacity in the world.

Wind power capacity is mainly spread across the Southern, Western and Northern regions

(Note: GW = Gigawatt, 1 GW = 1000 megawatt = 10^9 watts)

Wind power costs in India are decreasing rapidly. The levelised tariff of wind power reached a record low of ₹2.43 per kWh (without any direct or indirect subsidies) during auctions for wind projects in December 2017. However, the levelised tariff is increased to ₹2.77 per kWh in March 2021.

The potential is far from exhausted. Indian Wind Energy Association has estimated that with the current level of technology, the 'on-shore' potential for utilization of wind energy for electricity generation is of the order of 65,000 MW. The unexploited resource availability has the potential to sustain the growth of wind energy sector in India in the years to come.

Wind in India are influenced by the strong south-west summer monsoon, which starts in May-June, when cool, humid air moves towards the land; further, the weak north-east winter monsoon, which starts in October, when cool, dry air moves towards the ocean. During March- August, the winds are uniformly strong over the whole Indian Peninsula, except the eastern peninsular coast. Wind speeds during November-March are relatively weak, although high winds are available during a part of the period on the Tamil Nadu coastline.

WIND VELOCITY

Wind velocity is the measure of speed of wind in horizontal direction. Wind velocity means pedestrian level wind speed measured at 2 m above ground. It is a measure of air ventilation which has a direct effect on outdoor thermal comfort

WIND POWER

Kinetic energy exists whenever an object of a given mass is in motion with a translational or rotational speed.

When air is in motion, the kinetic energy in moving air can be determined as

$$E_k = 0.5 m \bar{u}^2 \dots (1)$$

Where m is the air mass and \bar{u} is the mean wind speed over a suitable time period.

The wind power can be obtained by differentiating the kinetic energy in wind with respect to time, i.e.

$$P_w = dE_k / dt = 0.5 \dot{m} \bar{u}^2 \dots (2)$$

However, only a small portion of wind power can be converted into electrical power.

When wind passes through a wind turbine and drives blades to rotate, the corresponding wind mass flow rate is

$$\dot{m} = \rho A \bar{u} \dots (3)$$

Where ρ is the air density and A is the swept area of blades

Substituting (3) into (2), the available power in wind P_w can be expressed as

$$P_w = 0.5 \rho A \bar{u}^3$$

MAJOR PROBLEMS ASSOCIATED WITH WIND POWER

Wind energy can have adverse environmental impacts, including the potential to reduce, fragment, or degrade habitat for wildlife, fish, and plants.

- Wind power must still compete with conventional generation sources on a cost basis i.e. wind projects must be able to compete economically with the lowest-cost source of electricity, and some locations may not be windy enough to be cost competitive.

- Good land-based wind sites are often located in remote locations, far from cities where the electricity is needed. Transmission lines must be built to bring the electricity from the wind farm to the city.
- Wind resource development might not be the most profitable use of the land. Land suitable for wind-turbine installation must compete with alternative uses for the land, which might be more highly valued than electricity generation.
- Turbines might cause noise and aesthetic pollution.
- Wind plants can impact local wildlife. Birds have been killed by flying into spinning turbine blades.

WIND MACHINES

Wind machines or wind turbines or wind energy converter, are the devices that converts the wind's kinetic energy into electrical energy. Wind turbines are manufactured in a wide range of sizes, with either horizontal or vertical axes.

Two important wind rotor configurations are as follows:

1. Vertical-axis wind turbines (VAWT), here the axis of rotation is vertical with respect to the ground (and roughly perpendicular to the wind stream). The following are the two main types of VAWT:

- Darrieus (which uses lift forces generated by aerofoil)
- Savonius (which uses drag forces)

2. Horizontal-axis wind turbines (HAWT), in which the axis of rotation is horizontal with respect to the ground (and roughly parallel to the wind stream). HAWT can be further divided into three types:

- Dutch windmills
- Multi-blade water-pumping windmills
- High-speed propeller-type wind machines

VERTICAL AXIS WIND MILLS/TURBINES

1. Vertical axis Darrieus wind turbine

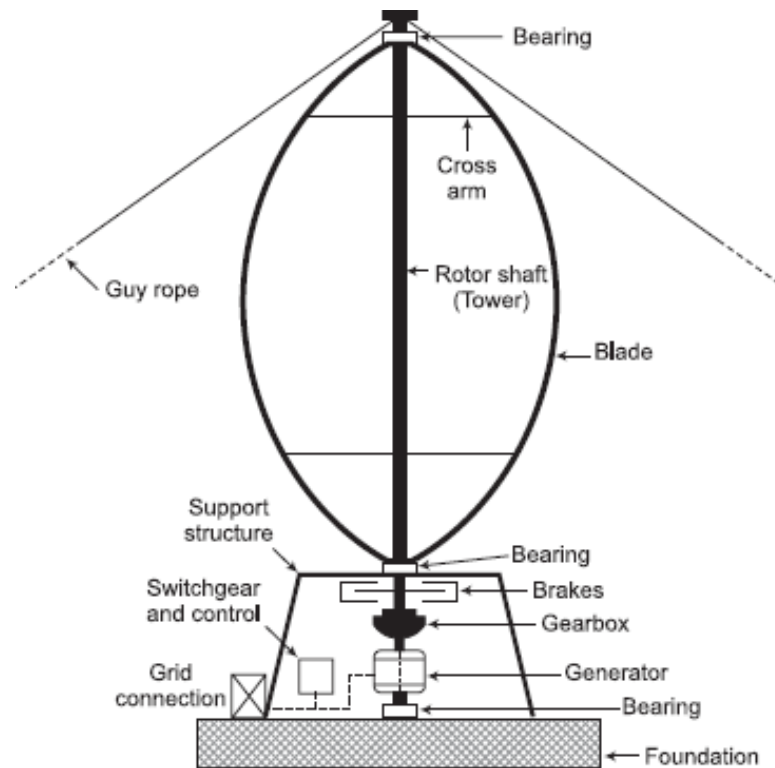

Fig 4.1: Vertical axis Darrieus wind turbine

• Constructional details

- Tower: The tower is a hollow vertical rotor shaft, which rotates freely about vertical axis between top and bottom bearings. It is installed above a support structure. The upper part of the tower is supported by guy ropes. The height of the tower of a large turbine is around 100 m
- Blades: It has two or three thin, curved blades shaped like an eggbeater in profile, with blades curved in a form that minimizes the bending stress caused by centrifugal forces-the so-called 'Troposkien' profile. The blades have airfoil cross section with constant chord length. The pitch of the blades cannot be changed.
- Support Structure: Support structure is provided at the ground to support the weight of the rotor. Gearbox, generator, brakes, electrical switchgear and controls are housed within this structure.
- The turbine consists of a number of aero foil usually but not always vertically mounted on a rotating shaft or framework
- Darrieus design, the aero foils are arranged so that they are symmetrical and have zero rigging angles, that is, the angle that the aero foils are set relative to the structure on which they are mounted.

- This arrangement is equally effective no matter which direction the wind is blowing—in contrast to the conventional type, which must be rotated to face into the wind.
- **Working principle**
 - In terms of operation, Darrieus utilizes the “lift” aerodynamic force to rotate.
 - By flowing around the structure, the wind creates suction on the front side of the turbine, driving the wings to rotate.
 - Because of the shape of the wings, they do not experience as much drag as Savonius turbines do. Once the rotation starts, Darrieus wind turbines are able to accelerate to rotate faster than the wind speed.
 - As the turbine tends to rotate, the electrical generator generates the electrical energy from the mechanical energy supplied by the rotation of rotor shaft.
- **Advantages**
 - The equipment (gear box and generator) can be placed close to the ground.
 - There is no need of a mechanism to turn the rotor against the wind
- **Disadvantages**
 - The efficiency is not very remarkable
 - The Darrieus is not a self-starting turbine, the starting torque is very low but it can be reduced by using three or more blades that result in a high solidity for the rotor.
 - Because wind speeds are close to the ground level, there is very low wind speed on the lower part of the rotor.
 - They are very difficult to mount high on a tower to capture the high level winds. Because of this, they are usually forced to accept the low, more turbulent winds, and they produce less in possibly more damaging winds.

2. Vertical axis Savonius wind turbine

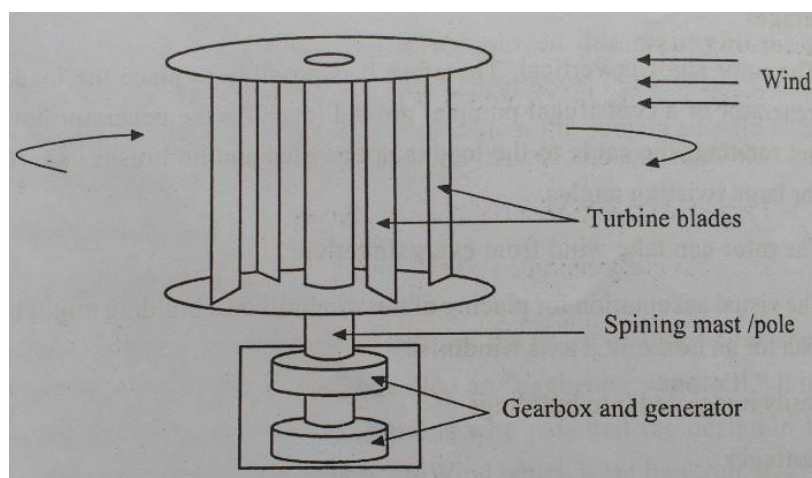

Fig 4.2: Vertical axis Savonius wind turbine

- **Constructional details**

- The Savonius wind turbine is a simple vertical axis device having a shape of half-cylindrical parts attached to the opposite sides of a vertical shaft (for two-bladed arrangement) and operate on the drag force, so it can't rotate faster than the wind speed.
- Aerodynamically, it is a drag-type device consisting of two or three scoops.
- Because of the curvature, the scoops experience less drag when moving against the wind than with the wind.

- **Working principle**

- The differential drag causes the Savonius turbine to spin.
- Because they are drag-type devices, Savonius turbines extract much less of the wind's power than other similarly sized lift-type turbines.
- As the wind blows into the structure and comes into contact with the opposite faced surfaces (one convex and other concave), two different forces (drag and lift) are exerted on those two surfaces.
- The basic principle is based on the difference of the drag force between the convex and the concave parts of the rotor blades when they rotate around a vertical shaft. Thus, drag force is the main driving force of the Savonius rotor

- **Advantages**

- Always self-starting, if there are at least three scoops
- Relatively easy to make

- **Disadvantages**

- Low efficiency: around 15%.

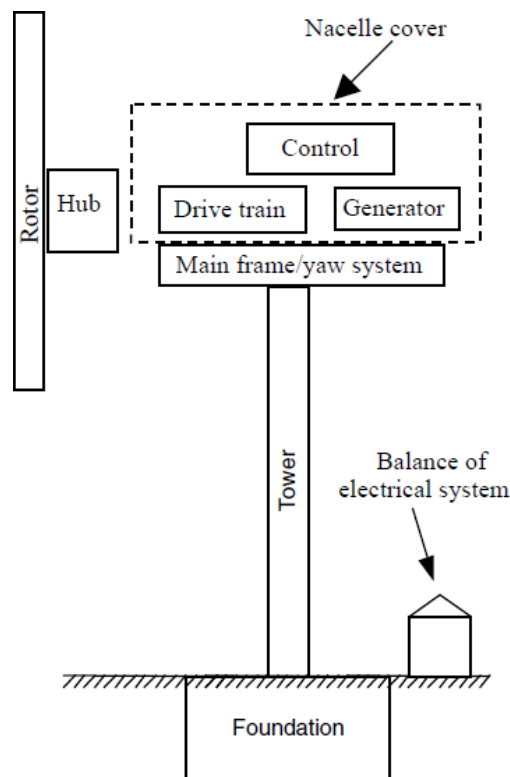
HORIZONTAL AXIS WIND TURBINE**Fig 4.3: Horizontal axis wind turbine**

- **Constructional details**

- The rotor consists of the hub and blades of the wind turbine. Most turbines today have upwind rotors with three blades
- The drive train consists of the other rotating parts of the wind turbine downstream of the rotor. These typically include a low-speed shaft (on the rotor side), a gearbox, and a high-speed shaft (on the generator side). Other drive train components include the support bearings, one or more couplings, a brake
- The purpose of the gearbox is to speed up the rate of rotation of the rotor from a low value (tens of rpm) to a rate suitable for driving a standard generator (hundreds or thousands of rpm).
- This category includes the wind turbine housing, the machine bedplate or main frame, and the yaw orientation system. The main frame provides for the mounting and proper alignment of the drive train components. The nacelle cover protects the contents from the weather
- This category includes the tower itself and the supporting foundation. The principal types of tower design currently in use are the free-standing type using steel tubes, lattice (or truss) towers, and concrete towers.
- A wind turbine control system includes the following components:
 - Sensors – speed, position, flow, temperature, current, voltage, etc.;

Controllers – mechanical mechanisms, electrical circuits;

Power amplifiers – switches, electrical amplifiers, hydraulic pumps, and valves;

Actuators – motors, pistons, magnets, and solenoids;

Intelligence – computers, microprocessors.

- In addition to the generator, the wind turbine system utilizes a number of other electrical components. Some examples are cables, switchgear, transformers, power electronic converters, power factor correction capacitors, yaw and pitch motors that forms the balance of electrical system
- **Working principle**
 - The horizontal-axis wind turbine (HAWT) is a wind turbine in which the main rotor shaft is pointed in the direction of the wind to extract power
 - The rotor receives energy from the wind and produces a torque on a low-speed shaft.
 - The low-speed shaft transfers the energy to a gearbox, high-speed shaft, and generator, which are enclosed in the nacelle for protection.
 - The low-speed shaft connects to the gearbox, which has a set of gears that increase the output speed of the shaft to approximately 1,800 rpm for an output frequency of 60 Hz (or a speed of 1,500 rpm if the frequency is 50 Hz).
 - The high-speed shaft is then connected to the generator, which converts the rotational motion to AC voltage.
- **Advantages**
 - High power output
 - High efficiency
 - Highly reliable
 - High operational wind speed
- **Disadvantages**
 - Difficult to transport, install and maintenance
 - Stronger impact on environment
 - Strict regulations to be followed

ELEMENTARY DESIGN PRINCIPLES

Wind turbine design is the process of defining the form and specifications of a wind turbine to extract energy from the wind. A wind turbine installation consists of the necessary systems needed to capture the wind's energy, point the turbine into the wind, convert mechanical rotation into electrical power, and other systems to start, stop, and control the turbine.

- **Aerodynamics:** The shape and dimensions of the blades of the wind turbine are determined by the aerodynamic performance required to efficiently extract energy from the wind, and by the strength required to resist the forces on the blade.
- **Power control:** The centrifugal force on the spinning blades increases as the square of the rotation speed, which makes this structure sensitive to over speed. A wind turbine is designed to produce power over a range of wind speeds. The cut-in speed is around 3–4 m/s for most turbines, and cut-out at 25 m/s. A control system involves three basic elements: sensors to measure process variables, actuators to manipulate energy capture and component loading, and control algorithms to coordinate the actuators based on information gathered by the sensors.
- **Stall:** A stall on an airfoil occurs when air passes over it in such a way that the generation of lift rapidly decreases. Usually this is due to a high angle of attack (AOA), but can also result from dynamic effects. The blades of a wind turbine with fixed pitch can be aerodynamically designed to stall in high wind speeds, causing slower rotation.
- **Furling:** Furling works by decreasing the angle of attack, which reduces the induced drag from the lift of the rotor, as well as the cross-section. A fully furled turbine blade, when stopped, has the edge of the blade facing into the wind.
- **Yawing:** Modern large wind turbines are typically actively controlled to face the wind direction measured by a wind vane situated on the back of the nacelle. By minimizing the yaw angle (the misalignment between wind and turbine pointing direction), the power output is maximized and non-symmetrical loads minimized
- **Turbine size:** For a given survivable wind speed, the mass of a turbine is approximately proportional to the cube of its blade-length. Wind power intercepted by the turbine is proportional to the square of its blade-length. The maximum blade-length of a turbine is limited by both the strength, the stiffness of its material, and transportation considerations.

COEFFICIENT OF PERFORMANCE OF A WIND MILL ROTOR

- It is the proportion of the power in the wind that the rotor can extract (it is also called power coefficient or efficiency; symbol C_p) and its variation as a function of tip-speed ratio is commonly used to characterize different types of rotor.
- It is physically impossible to extract all the energy from the wind, without bringing the air behind the rotor to a standstill.
- Consequently, there is a maximum value of C_p of 59.3% (known as the Betz limit), although in practice, real wind rotors have maximum C_p values in the range of 25%-45%.

- The performance coefficient of a rotor is the fraction of wind energy passing through the rotor disc, which is converted into shaft power. This is a measure of the efficiency of the rotor and it varies with the tip-speed ratio.

AERODYNAMIC CONSIDERATIONS IN WIND MILL DESIGN

The VAWT and HAWT use either lift or drag forces to harness the wind. Out of these types, the horizontal-axis lift device is the most commonly used. In fact, other than a few experimental machines, virtually all windmills come under this category.

There are two primary physical principles by which energy can be extracted from the wind. These are through the creation of either lift or drag force (or through a combination of the two), as shown in the below figure

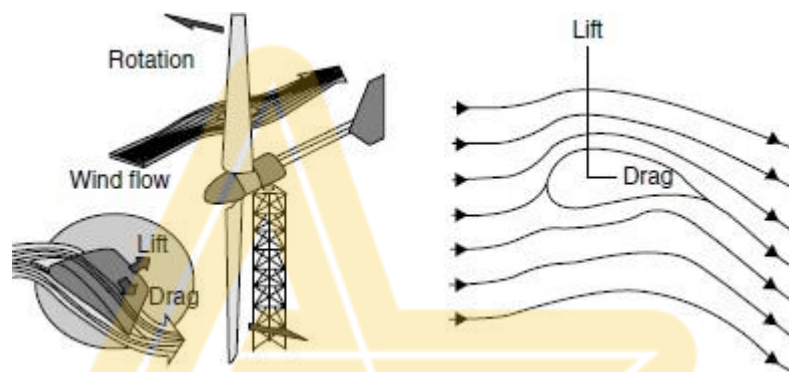

Fig 4.4: Principles of wind turbine aerodynamics

Air flow over a stationary airfoil produces two forces, a lift force perpendicular to the air flow and a drag force in the direction of air flow, as shown in the above figure.

The existence of the lift force depends upon laminar flow over the airfoil, which means that the air flows smoothly over both sides of the airfoil. If turbulent flow exists rather than laminar flow, there will be little or no lift force.

The air flowing over the top of the airfoil has to speed up because of a greater distance to travel and this increase in speed causes a slight decrease in pressure. This pressure difference across the airfoil yields the lift force, which is perpendicular to the direction of air flow. The air moving over the airfoil also produces a drag force in the direction of the air flow. This is a loss term and is minimized as much as possible in high-performance wind turbines

- **Lift Force:** The lift force (F_L) arises in a direction that is perpendicular to the airstream caused by Bernoulli's effect that lowers the pressure on the top of the airfoil when compared with the pressure on its bottom. The curvature on the top leads to a higher stream velocity than at the bottom and hence a lower pressure.

Let (F_L) is the lift force in Newton, (S_L) is the cross-sectional area of airfoil in m^2 , ρ is the air density in kg/m^3 , and V is the wind speed in m/s . Then, lift coefficient (C_L) is

defined as follows

$$C_L = [F_L/S_L] / [(1/2) \rho V^2]$$

- **Drag force (F_D):** It is described as follows, Where C_D = drag coefficient and S_D = Effective area of airfoil in the direction of drag force.

$$C_D = [F_D/S_D] / [(1/2) \rho V^2]$$

- The lift and drag force vary with the angle that rotor blade makes with the direction of wind stream. This angle is called as angle of attack. The resultant of drag and lift forces constitute the thrust force that effectively rotate the blade.

NUMERICAL

A three-bladed wind rotor with blade length of 52 m is operating in a wind stream having wind velocity of 12 m/s. Air density is 1.23 kg/m³ and power coefficient may be taken as 0.4. Calculate the extractable power from the wind.

Solution:

Given data are as follows:

Blade length, $L = 52$ m; wind speed, $v = 12$ m/s; air density, $\rho = 1.23$ kg/m³; power coefficient, $C_p = 0.4$.

Thus, $A = \text{swept area} = \Pi r^2 = \Pi (52)^2 = 8495 \text{ m}^2$

$$P_{\text{Available}} = C_p (1/2 \rho A v^3) = 0.4 \times 1/2 \times 1.23 \times 8495 \times (12)^3 = \mathbf{3.6 \text{ MW}}$$

TIDAL ENERGY

Tidal energy is produced by the surge of ocean waters during the rise and fall of tides. Tidal energy is a renewable source of energy harnessed by converting energy from tides into useful forms of power, mainly electricity using various methods.

TIDES AND WAVES AS ENERGY SUPPLIERS AND THEIR MECHANICS

- Tidal power is taken from the Earth's oceanic tides. Tidal forces are periodic variations in gravitational attraction exerted by celestial bodies. These forces create corresponding motions or currents in the world's oceans.
- Due to the strong attraction to the oceans, a bulge in the water level is created, causing a temporary increase in sea level.
- As the Earth rotates, this bulge of ocean water meets the shallow water adjacent to the shoreline and creates a tide. This occurrence takes place in an unending manner, due to the consistent pattern of the moon's orbit around the earth.
- The magnitude and character of this motion reflects the changing positions of the Moon and Sun relative to the Earth, the effects of Earth's rotation, and local geography of the seafloor and coastlines.
- The rise of seawater is called high tide and fall in seawater is called low tide and this process of rising and receding of water waves happen twice a day and cause enormous movement of water. Thus, enormous rising and falling movement of water is called tidal energy, which is a large source of energy and can be harnessed in many coastal areas of the world.

FUNDAMENTAL CHARACTERISTICS OF TIDAL POWER

- Tidal power or tidal energy is a form of hydropower that converts the energy obtained from tides into useful forms of power, mainly electricity.
- Although not yet widely used, tidal energy has potential for future electricity generation.
- Tidal power is the only technology that draws on energy inherent in the orbital characteristics of the Earth–Moon system, and to a lesser extent in the Earth–Sun system.
- Greater tidal variation and higher tidal current velocities can dramatically increase the potential of a site for tidal electricity generation.
- Tidal power is also relatively prosperous at low speeds, in contrast to wind power. Water has one thousand times higher density than air and tidal turbines can generate electricity at speeds as low as 1m/s, or 2.2mph.

- Tidal energy is clean, renewable, and sustainable form of energy resource. It has no impact on climate because it does not produce any greenhouse gases.

HARNESSING TIDAL ENERGY

- **Tidal stream generator:** Tidal stream generators make use of the kinetic energy of moving water to power turbines, in a similar way to wind turbines that use the wind to power turbines. Some tidal generators can be built into the structures of existing bridges or are entirely submersed, thus avoiding concerns over the impact on the natural landscape.
- **Tidal barrage:** Tidal barrages make use of the potential energy in the difference in height (or hydraulic head) between high and low tides. When using tidal barrages to generate power, the potential energy from a tide is seized through the strategic placement of specialized dams. When the sea level rises and the tide begins to come in, the temporary increase in tidal power is channeled into a large basin behind the dam, holding a large amount of potential energy. With the receding tide, this energy is then converted into mechanical energy as the water is released through large turbines that create electrical power through the use of generators
- **Dynamic tidal power:** Dynamic tidal power (or DTP) is a theoretical technology that would exploit an interaction between potential and kinetic energies in tidal flows. It proposes that very long dams (for example: 30–50 km length) be built from coasts straight out into the sea or ocean, without enclosing an area
- **Tidal lagoon:** A new tidal energy design option is to construct circular retaining walls embedded with turbines that can capture the potential energy of tides. The created reservoirs are similar to those of tidal barrages, except that the location is artificial and does not contain a pre-existing ecosystem. The lagoons can also be in double (or triple) format without pumping or with pumping that will flatten out the power output.

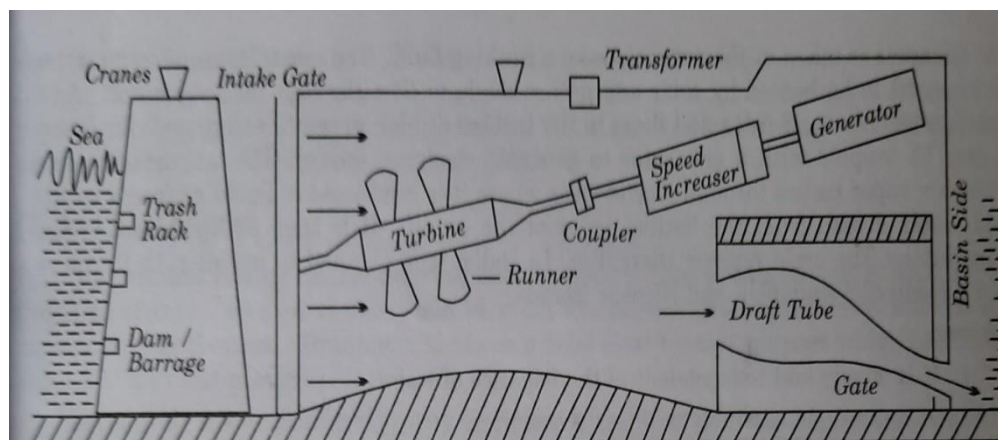

Fig: 4.5: Schematic layout of tidal power house

The above layout is the tidal power house or tidal power plant that consists of a barrage built across the tidal reach to create pool in which water can be stored. Inside the barrage reversible water turbines and flood gates are installed. During the occurrence of high tide and low tides, the flood gates open and close respectively.

One tide cycle is identified as the shift from low tide to high tide and back to low tide. The time duration to complete one tidal cycle is approximately 12.5 hours. During this period the pool is filled and empties. These may be classified as single basin system and double basin system

LIMITATIONS

- Economic recovery of energy from tides is feasible only at those sites where energy is concentrated in the form of tidal range of about 5 m or more and geography provide favorable site for economic construction of a tidal plant, thus it is site specific
- Due to mismatch of lunar driven period of 12.5 hours and human (solar) period of 24 hours, the optimum tidal power generation is not in phase with demand
- Changing tidal range in two weeks period produces changing power
- The turbines are required to operate at variable heads
- Requirement of large water volume flow at low head necessitates parallel operation of many turbines
- Tidal plant disrupts marine life at the location and can cause potential harm to ecology
- It requires very large capital cost at most potential installations
- The location of sites may be distant from the demand centers

OCEAN THERMAL ENERGY

About 70% of earth's surface is covered by ocean which is continuously heated by solar heat. Solar heat is stored as uneven distribution of heat between warm surface water and cold deep ocean water (called gradient) from where it is harnessed as ocean thermal energy

PRINCIPLE OF WORKING

The basic principle of ocean thermal energy conversion (OTEC) is explained as follows:

Closed cycle OTEC

- The warm water from the ocean surface is collected and pumped through the heat exchanger to heat and vaporize a working fluid, and it develops pressure in a secondary cycle.
- Then, the vaporized working fluid expands through a heat engine (similar to a turbine) coupled to an electric generator that generates electrical power.
- Working fluid vapor coming out of heat engine is condensed back into liquid by a condenser.
- Cold deep ocean water is pumped through condenser where the vapor is cooled and returns to liquid state.
- The liquid (working fluid) is pumped again through heat exchanger and cycle repeats. It is known as closed-cycle OTEC.

Open cycle OTEC

- If ocean surface water is high, enough propane or similar material is used as working fluid; otherwise, for low-temperature surface water, fluid such as ammonia with low boiling point is used.
- In an open-cycle OTEC, warm ocean surface water is pumped into a low-pressure boiler to boil and produce steam.
- Then, the steam is used in steam turbine to drive an electrical generator for producing electrical power. The cold deep sea water is used in condenser to condense steam.
- Some fractions of electrical power generated by OTEC plants are used for operating and controlling equipment involved in power plants, and high electrical power is used for feeding to several other energy consumers.

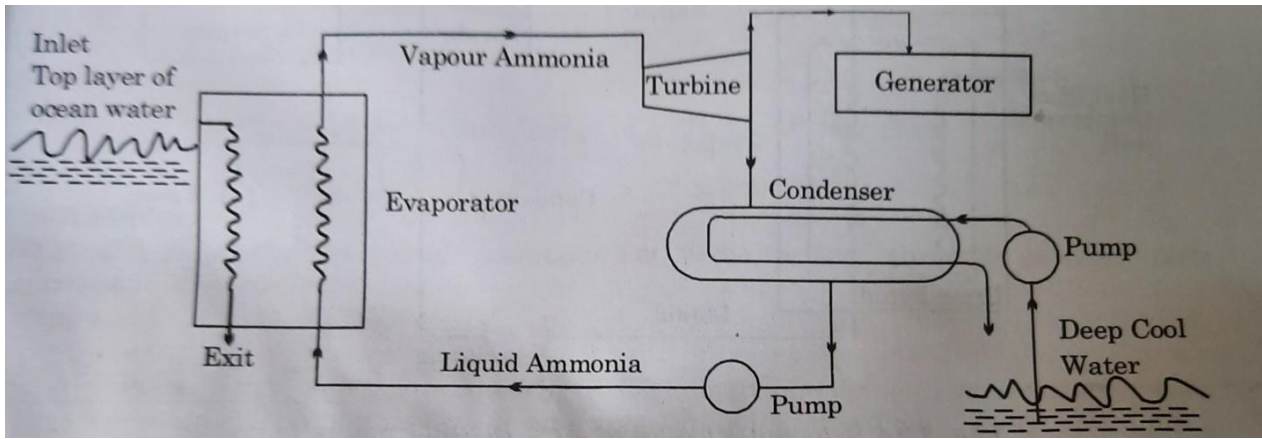

Fig 4.6: Ocean thermal energy conversion – open cycle system

The above unit represents the open cycle type of ocean thermal energy conversion system that consists of an evaporator, a turbine, a generator, a condenser and two pumps.

A low boiling point liquid i.e. ammonia is taken into the evaporator as a working fluid. The upper layers of ocean water which need to be heated by solar energy are made to flow through the evaporator. As a result, ammonia evaporates and flows to the turbine at high pressure and propels it.

Later it may be coupled with a generator to generate electrical energy.

The low pressure exit ammonia vapor passes through the condenser where it is condensed to liquid ammonia by the cold water drawn from the bottom layer of the ocean. It is then pumped back to the evaporator. The cycle repeats thereafter.

RANKINE CYCLE

The basic Rankine cycle shown in the below Figure that consists of an evaporator, a turbine expander, a condenser, a pump, a working fluid

- In open-cycle OTEC, warm sea water is used as working fluid, whereas in closed-cycle type, low-boiling point ammonia or propane is used.

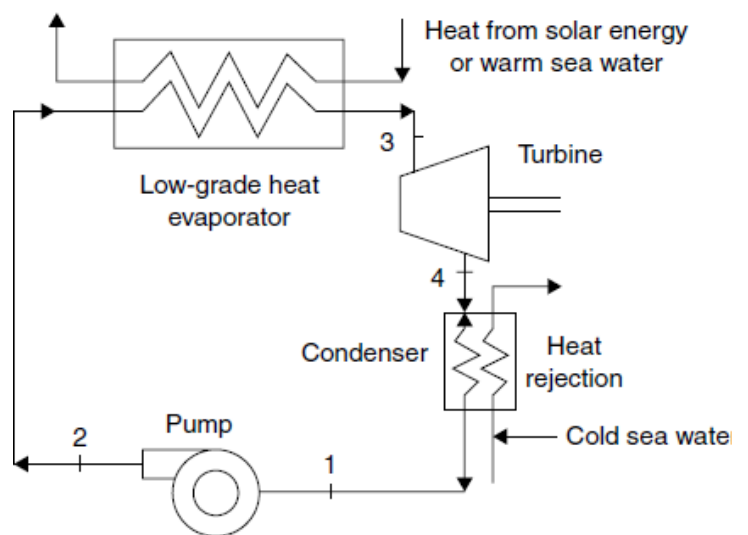

Fig 4.7: OTEC Rankine Cycle

- Warm ocean surface water flows into the evaporator which is the high-temperature heat source. A fluid pump is utilized to force the fluid in a heat evaporator where liquid fluid vaporizes.
- Then, the vapor of boiling fluid enters the turbine expander coupled with an electrical generator to generate electrical power.
- The vapor released from the turbine enters into condenser where it condenses. The cold deep sea water is pumped through the condenser for heat rejection from vapor fluid and condenses it as liquid fluid.
- The liquid fluid is again pumped through evaporator and cycle repeats. As temperature difference between high- and low-temperature ends is large enough, the cycle will continue to operate and generate power.

OTEC POWER STATIONS IN THE WORLD

- Makai Ocean Engineering's ocean thermal energy conversion (OTEC) power plant in the US is the world's biggest operational facility of its kind with an annual power generation capacity of 100kW, which is sufficient to power 120 homes in Hawaii.
- OTEC plant in Japan overseen by Saga University

PROBLEMS ASSOCIATED WITH OTEC

- **High cost:** Electricity generated by OTEC plants is more expensive than electricity produced by chemical and nuclear fuels.
- **Complexity:** OTEC plants must be located where a difference of about 20°C occurs year round. Ocean depths must be available fairly close to shore-based facilities for economic operation. Floating plant ships could provide more flexibility.
- **Acceptability:** For the large-scale production of electricity and other products, OTEC plants are poorly acceptable due to their high costs.
- **Ecosystem damage:** It is obvious by setting OTEC plants.
- **Lower efficiency:** A higher temperature difference between ocean surface warm water and cold deep ocean water is required for highly efficient operation of plant.

INTRODUCTION

Geothermal energy originates from earth's interior in the form of heat. Volcanoes, geysers, hot springs and boiling mud pots are visible evidence of the great reservoirs of heat that lies within earth. Although the amount of thermal energy within the earth is very large, useful geothermal energy is limited to certain sites only, as it is not feasible to access and extract heat from a very deep location. The sites where it is available near the surface and is relatively more concentrated, its extraction and use may be considered feasible. These sites are known as geothermal fields. As per US Geological Survey, the entire heat content of the earth's crust up to a depth of 10 km above 15 °C is defined as geothermal resource. As such the geothermal resource is estimated to be more than 2.11×10^{25} J, which is equivalent to 109 MTOE (million tons of oil equivalent). This is a huge amount of energy, enough to supply our energy needs at current rates for 3,50,000 years. Thus it is considered an inexhaustible and renewable source. However, it is a low-grade thermal energy form and its economic recovery is not feasible everywhere on the surface of the earth. Practically it is not the size of the resource that limits its use but the availability of technology that can tap the resource in an economic manner.

Low temperature resources, i.e. "geysers" have been used from time immemorial for applications such as therapeutic hot baths, cooking, space and water heating. Most geothermal resources produce low-grade heat at about 50–70 °C, which can be used directly for thermal applications. Occasionally, geothermal heat is available at temperatures above about 90 °C, and so electrical power production from turbines can be contemplated. World's total present (end of year 2012) installed electrical power generating capacity from geothermal resource is about 11,490 MWe and direct thermal use installed capacity is 50,000 MWt. Globally, geothermal power is growing steadily at a rate of about 5 per cent per year. The annual growth in energy output over the past five years has been 3.8 per cent for electricity production and around 10 per cent for direct use (including geothermal heat pumps. The geothermal electrical energy production in El Salvador is 25 per cent of the country's total production. At present the capital cost of a geothermal power plant is about Rs. 150–375 crore (Euro 2–5 million) per MWe of electric capacity. The geothermal electricity cost is about Rs 3–7.5 (Euro 0.01 to 0.1) per kWh.

TYPES OF GEOTHERMAL RESOURCES

There are four types of geothermal resources: (i) hydrothermal, (ii) geo-pressured, (iii) hot dry rock (HDR) and (iv) magma. At present the technology for economic recovery of energy is available for hydrothermal resource only. Thus this is the only commercially used resource at present. Other resources are going through development phase and have not become commercial so far.

Hydrothermal Resources Hydrothermal resources arise when underground water has access to high temperature porous rocks, capped by a layer of solid impervious

rock. Thus water is trapped in the underground reservoir (aquifers) and is heated by surrounding rocks. Heat is supplied by magma by upward conduction through solid rocks below the reservoir. Thus it forms a giant underground boiler. Under high pressure, the temperature can reach as high as 350 °C. The hot water often escapes through fissures in the rock, thus forming hot springs or geysers. Sometimes steam escapes through cracks in the surface. These are called fumaroles. In order to utilize the hydrothermal energy, wells are drilled either to intercept a fissure or, more commonly into the hydrothermal reservoir as shown in Fig.

Figure: General simplified structure of hydrothermal resource

The hydrothermal resources are located at shallow to moderate depths (from approximately 100 m to 4,500 m). Temperatures for hydrothermal reserves used for electricity generation range from 90 °C to 350 °C but roughly two-thirds are estimated to be in the moderate temperature range (150 °C to 200 °C).

For practical purposes, hydrothermal resources are further subdivided into

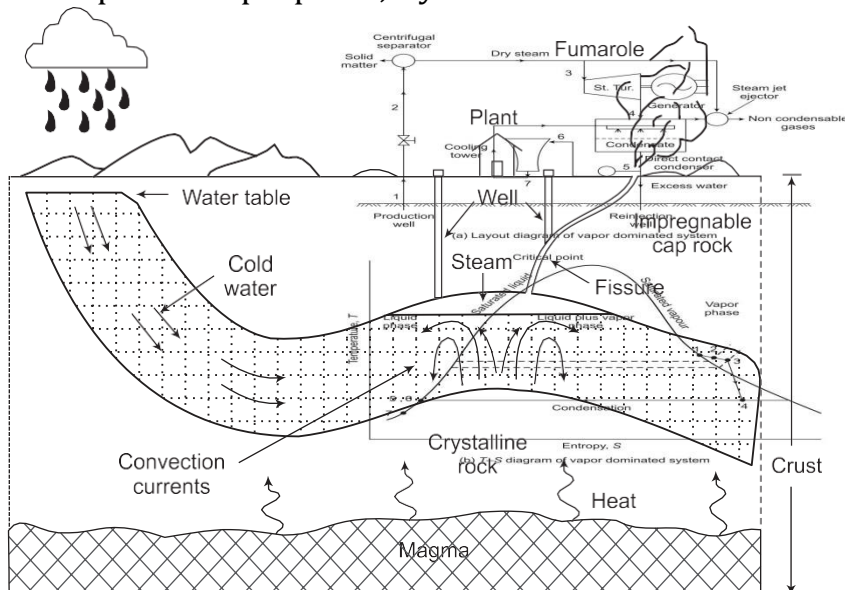

(i) vapour dominated (dry steam fields), (ii) liquid dominated (wet steam fields) and hot water resource. Vapour dominated fields deliver steam with little or no water and liquid dominated fields produce mixture of steam and hot water or hot water only. The system to utilize the energy depends on the type of resource.

Vapour Dominated (Dry Steam) System

Dry steam fields occur when the pressure is not much above the atmospheric pressure and the temperature is high. Water boils underground and generates steam. The most important known dry steam fields are: (a) "The geysers" regions in California, which may be the largest, (b) the Larderello and some smaller areas in Italy and (c) a small field (or fields) at Matsukawa, Japan. Dry steam field at Larderello is especially ideal because its wells produce virtually pure steam with no water.

The layout of vapor-dominated system is shown in Fig(a). The operation is explained with the help of T-S diagram given in Fig.(b). The steam is extracted from the well (1) where it is nearly saturated. The extracted steam is then cleaned in centrifugal separator to remove solid matter. While passing through the well, as well as centrifugal separator the pressure drops, which causes it to slightly super heat. The steam is then supplied to a turbine (3) at temperature of about 165 °C and pressure of about 7.8 atm. (the temperature and pressure in the reservoir are higher) and allowed to expand (4). The exhaust steam of turbine is condensed in direct contact condenser, in which the steam is condensed by direct contact with cooling water. The resulting warm water (5) is circulated and cooled in cooling tower and returned to the condenser (7). The condensation of steam continuously increases the volume of cooling water. Excess water is reinjected at some distance deep into the ground for disposal. The non-condensable gases are removed from the condenser by steam jet ejection.

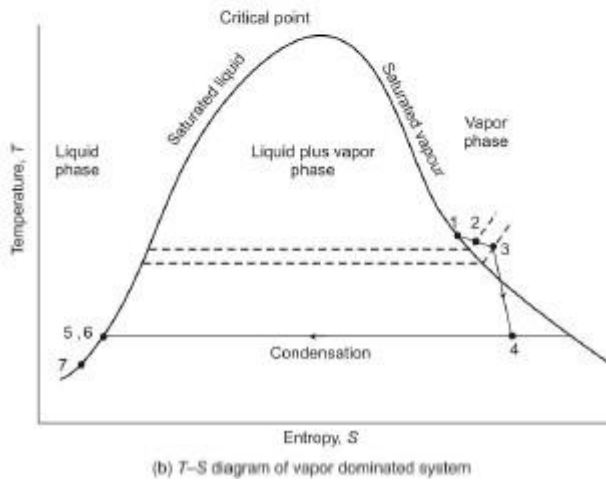
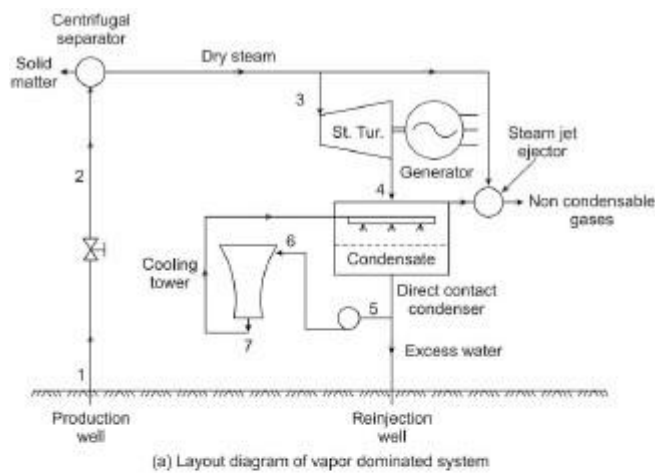

Figure: Dry steam hydrothermal system

Liquid Dominated (Wet Steam) System

Steam plants are the most cost-effective technology, when the resource temperature is above about 175 °C. Therefore, liquid dominated or wet steam fields may further be subdivided into (a) high temperature (above 175 °C), where steam plants can be used and (b) low temperature (below 175 °C) fields where other technologies are used.

Liquid Dominated – High Temperature System In high temperature liquid dominated reservoir, water temperature is above 175 °C; however, it is under high pressure and remains in liquid state. The most extensive development has been in the volcanic Wairakei field in New Zealand, the first of its kind, was built in 1958. In this field the reservoir temperature and pressures are 230 °C and 40 atm respectively and depths are 600 m to 1400 m.

When water is brought to the surface and pressure is reduced, rapid boiling occurs and it “flashes” into steam and hot water. The operation of single flash system is illustrated in Fig. 9.5. The hot water from the well (1) is brought to well head

(2) at a lower pressure. Process 1–2 is essentially a constant enthalpy throttling process that results in a two-phase mixture of low quality at 2. This is throttles further in a flash separator (3) to get a two-phase mixture of slightly higher quality. This mixture is now separated into dry saturated steam at 4 and saturated brine at 5. The highly saline hot water (known as brine) can be used for direct heat and then reinjected into the ground. The separated steam at 4 is expanded in a turbine to 6. The maximum initial steam temperature is about 175 °C and the gauge pressure is 3.5 atm. The exhaust steam at 6 is mixed with cooling water in a direct contact condenser and the resulting mixture at 7 is directed to a cooling tower.

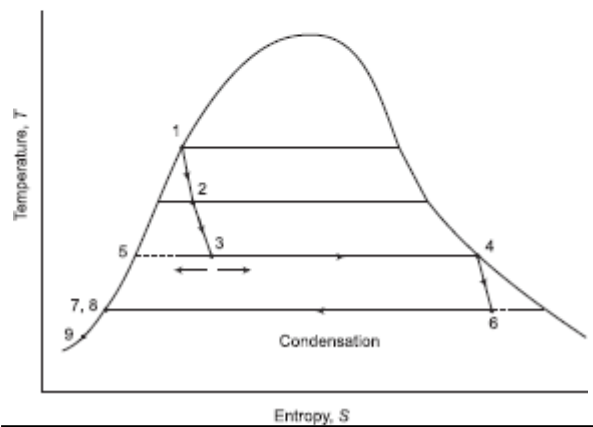
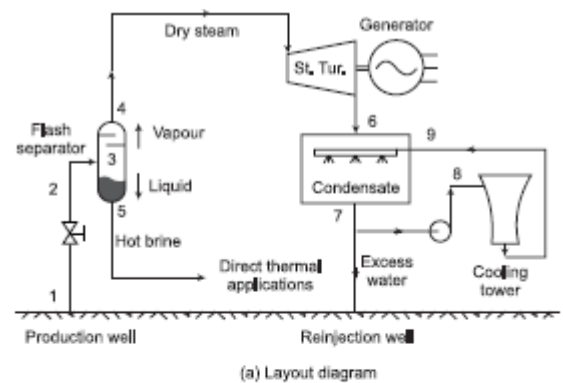

Single flash, wet steam high temperature hydrothermal system

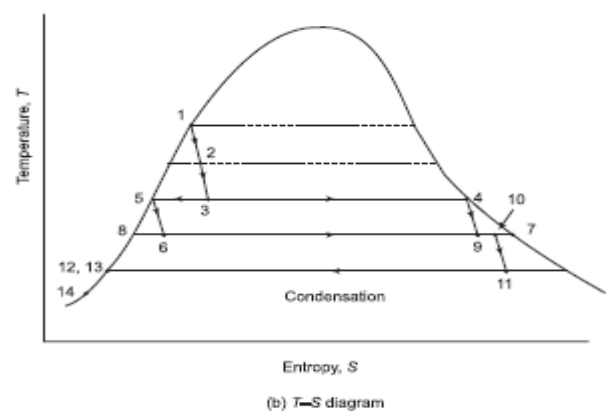
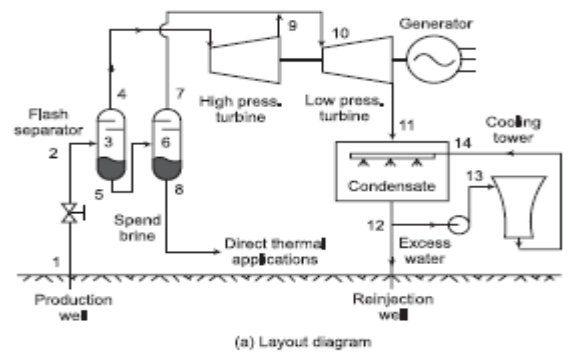

Double flash, wet steam high temperature hydrothermal system

In dual flash systems, the steam is flashed a

second time from the remaining hot fluid of the first stage, separated and fed into dual inlet turbine or into two separate turbines. The efficiency of such a plant is around 8 per cent. The layout of double flashed systems along with T-S diagrams is shown in Fig. 9.6. The 50 MWe Hatchobane plant, Kyushu in Japan is a double flash system.

As of 2013, the largest liquid system is Cerro Prieto in Mexico, which generates 750 MWe from temperatures reaching 350 °C (662 °F). The Salton Sea field in Southern California offers the potential of generating 2000 MWe. Such systems are also being implemented in Philippines and other places.

A third approach is called Total Flow Concept, in which a special mixed phase turbine is used that would utilize both the kinetic energy as well as heat energy of the two-phase (steam-liquid) mixture produced by flashing the geothermal brine. The overall efficiency in such a system should be greater than other methods where only heat content of the brine is utilized. A layout and corresponding T-S diagram of total flow power plant is given in Fig. 9.7. The hot fluid from geothermal well (1) is throttled to get a two-phase mixture of low quality at 2. At this point the two phases are not separated, and the total flow is piped to turbine and allowed to expand to the discharge is condensed to 4 in direct contact condenser. The excess brine is reinjected to ground.

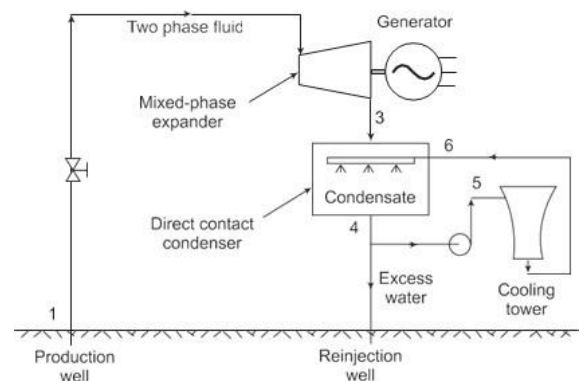

(a) Layout diagram

Liquid Dominated – Low Temperature System These resources are available at moderate temperature range of 90 °C – 175 °C. They are common in extensional terrains, where heating takes place via deep circulation along faults, such as in the

Western US and Turkey. This temperature is not enough for efficient flash steam production and requires pumping. A binary-fluid system is employed, where the

heat of geothermal fluid is used to vapourize a volatile organic fluid, such as isobutene (B.P. 10 °C), under pressure in a primary heat exchanger. The geothermal fluid is reinjected after extraction of heat. This vapourized fluid serves as working fluid in a Rankine cycle plant. The exhaust vapour from the turbine is cooled in the regenerative heat exchanger and then condensed in a condenser. The condensed liquid isobutene is returned to primary heat exchanger by way of the regenerative heat exchanger. These binary plants originated in the Soviet Union in late 1960s and predominate in new US plants. The layout of the system is shown in Fig. 9.8. Binary plants have no emissions.

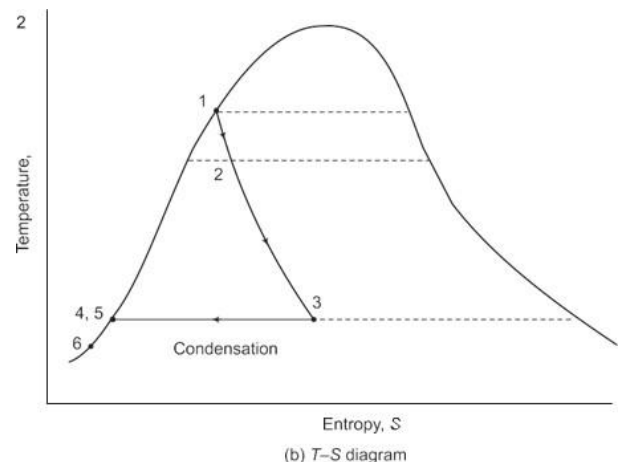

(b) T-S diagram

The thermal efficiency of such a plant is typically about 10–13 per cent. These plants do not produce any steam condensate and have to rely on external source of cooling water or air-cooling.

Such plants are in use at East Mesa, Mammoth Lake in California and other places in USA, Kawerau, New Zealand and many other places in the world. Presently some 1790 MWe binary power plants are in operation worldwide [52].

Main advantages of binary systems are: (i) they almost avoid corrosion, scaling and environmental problems as the geothermal fluid circulates through a closed-cycle and all the fluid is reinjected and (ii) in many cases, they are capable of higher conversion efficiencies than flash steam plants.

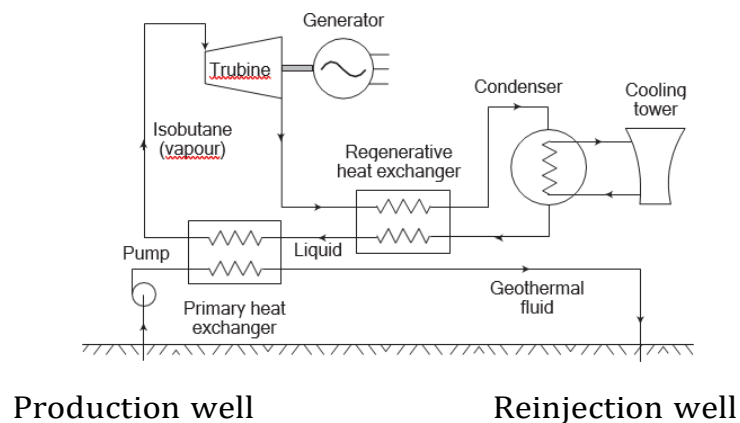

3. Hot Water System

Hydrothermal reservoirs of low to moderate temperatures (20 °C–150 °C) can be used to provide direct heat for residential and industrial uses. The hot water is brought to the surface where a heat exchanger system transfers its heat to another fluid (liquid or air); although the resource can be used directly if the salt and solid content is low. The geothermal fluid is reinjected into the ground after extraction of heat. The heated fluid transports heat to the place of use. Recent surveys have identified a large potential for direct use geothermal applications. Iceland is the world leader in direct applications. Some 92.5 per cent of its homes are heated with geothermal energy, saving Iceland over \$100 million annually in avoided oil imports. Reykjavík, Iceland has the world's biggest district heating system. Once known as the most polluted city in the world, it is now one of the cleanest.

Energy of hot water resource can also be utilized in a hybrid system consisting of geothermal–conventional thermal (fossil fuel or biomass based) system. In this system, hot water resource is used to preheat feed water and / or air for combustion. Geothermal heat replaces some or all of the feed water heaters, depending upon its temperature. A 30 MWe geothermal-wood waste hybrid plant is in operation at Honey Lake, California since 1989.

4. Geo-pressured Resources

While drilling for oil and gas, hot salty water (brine) reservoirs, at moderately high temperature, (90 °C to 200 °C), and under great pressure are found at a depth of 3 to 6 km. Because of the very high pressure of the water, up to 1350 atm in the deepest layer, these reservoirs are referred to as geo-pressured. A special feature of geo-pressured water is that it also contains a significant amount of dissolved methane gas, usually

1.9 – 3.8 m³ per m³ of water. The solubility of methane in water at normal pressure is quite low, but it increases with pressure. When the water is brought to the surface and its pressure reduced, the methane gas is released from the solution. Thus methane can be extracted from brine by simple and economical gravity separation technique. This resource is potentially very promising because three types of energy can be extracted from the wells: (i) thermal energy from the heated fluids, (ii) mechanical (hydraulic) energy from the high pressures involved and (iii) chemical energy from burning of methane gas.

The extent of geo-pressured reserves is not yet well known worldwide, and the only major resource area identified to date is along the Texas and Louisiana coast of the Gulf of Mexico. The belt is about 1200 km in length along the coast and extends up to about 160 km inland and 240 km offshore. The potential of geo-pressured resource of this area has been estimated as 23 to 240 GWe for 30 years. Experimental wells are already in place in Texas and Louisiana. A hybrid geo-pressured conversion unit (1 MWe) was successfully operated in 1990 as a demonstration unit. Studies are underway to identify reservoirs with sufficient volume and permeability to sustain large water flows over long time periods and the extent of dissolved methane gas.

There are regions underground at temperatures exceeding 200 °C, with little or no water. The rocks are impermeable and/or there is no surface water in the vicinity. Such resources up to a depth of 5 km are estimated to be significant and worthy of development as a source of energy. Hot dry rocks are much more common than hydrothermal reservoirs and more accessible, so their potential is quite high.

The recovery of heat from HDR involves forming a man-made reservoir by drilling deep into the hot rocks and then cracking it to form cavity or fractures. Such a system is known as “Enhanced Geothermal Systems” (EGS), also sometimes called engineered geothermal systems. This can be achieved by (i) detonating high explosive

at the bottom of the well, (ii) nuclear explosion or (iii) hydraulic fracturing. Hydraulic fracturing, which is performed by pumping of water at high pressure into the rock formation, is commonly used in oil and gas fields to improve the flow. It appears that the quantity of conventional explosives required would be uneconomically large, nuclear explosives are associated with environmental and safety issues and therefore hydraulic fracturing seems to be more promising.

To recover heat, water is pumped into the cracks from the surface, and withdrawn by another well at a distance. Injection and production wells are joined to form a circulating loop through this man-made reservoir to achieve a steady flow of high temperature water (or water–steam mixture). Electricity can be generated by binary fluid system as shown in Fig. 9.9. When heat is extracted, the rock cools down and new cracks are developed due to temperature gradient. Thus the resource keeps on expanding. The technique was tested at a location near Valles Caldera, USA, where fractures were made at a depth of about 2.76 km. The temperature at the location was 185 °C. Freon (R-114) was used as working fluid for turbine in a binary system. Only 5 per cent of the water introduced was lost in the ground and small proportion of makeup water was required. The largest EGS project in the world is a 25 MWe demonstration plant currently (year 2015) being developed in the Cooper Basin, Australia – with the potential to generate 5,000–10,000 MW.

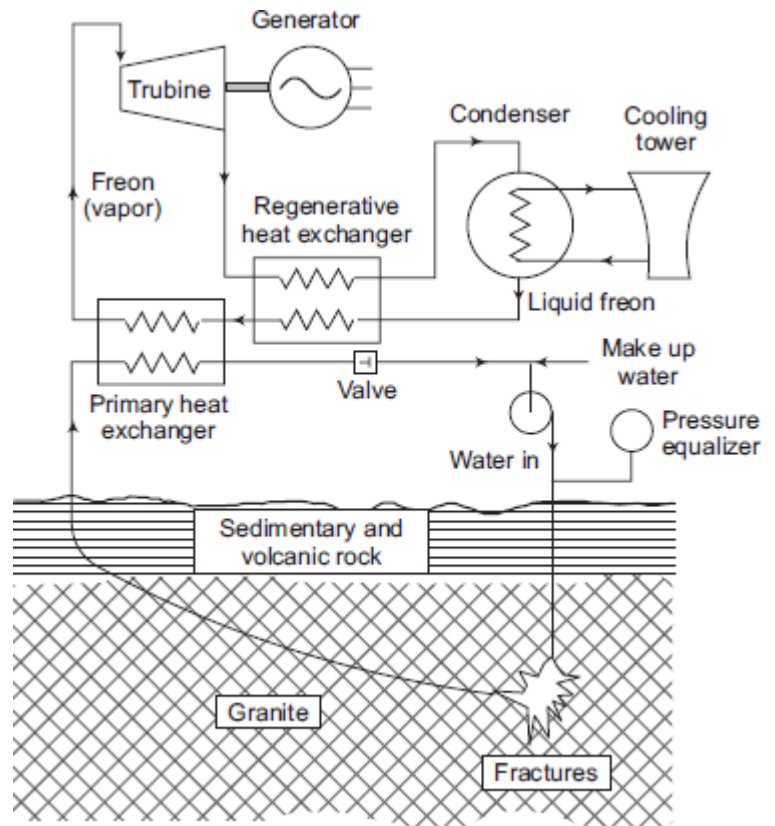

At some places, molten or partially molten rock (magma chamber), at temperatures 650 °C to 1,200 °C, occurs at depths 5 km – 10 km. These resources are located, especially in the vicinity of recent volcanic activity (e.g. Hawaii). Very high temperature and large volume make magma a huge potential energy source, the largest of all geothermal resources. However, successful magma drilling technology has not been established yet. Extracting magma energy is expected to be the most difficult of all resource types. Magma technology will require special drilling technology to deal with the interaction of the drill bit with molten rock, the effects of dissolved gases, and mechanisms of heat transport in molten magma. This resource has not been developed as yet.

GEOTHERMAL ENERGY IN INDIA

Though India has been one of the earliest countries to begin geothermal projects way back in the 1970s, but at present there are no operational geothermal plants in India. There is also no installed geothermal electricity generating capacity as of now and only direct uses (e.g. drying) have been detailed.

A systematic collaborative, research, development and demonstration program is undertaken with different organizations, viz., IIT Delhi, National Aeronautic Limited, Bangalore, Geological Survey of India, National Geophysical Research Institute (NGRI), Hyderabad, Oil & Natural Gas Corporation, etc. As a result of various resource assessment studies/surveys, nearly 350 potential hot springs, distributed in seven geothermal provinces, have been identified throughout the country. These springs are perennial and their surface temperatures range from 37 to 90 °C with a cumulative surface discharge of over 1000 l/min. Most of them are low temperature hot water resources and can best be utilized for direct thermal applications. Only some of them can be considered suitable for electrical power generation. The potential for power generation at these sites has been estimated as about 10,600 MW. The use of geothermal energy has already been demonstrated in the country for small-scale power generation and thermal applications. Small direct heat pilot plants have been installed at Puga and Chumathang (in Ladakh, Jammu and Kashmir) and Manikaran (H.P.), etc.

The seven geothermal provinces include, The Himalayas: Sohana: West coast: Cambay: Son–Narmada–Tapi (SONATA): Godavari and Mahanadi. These provinces are associated with major rifts or subduction tectonics and registered high heat flow and high geothermal gradient. The locations of geothermal fields in the country are shown in Fig. 9.12. The heat flow values and thermal gradients at these locations are

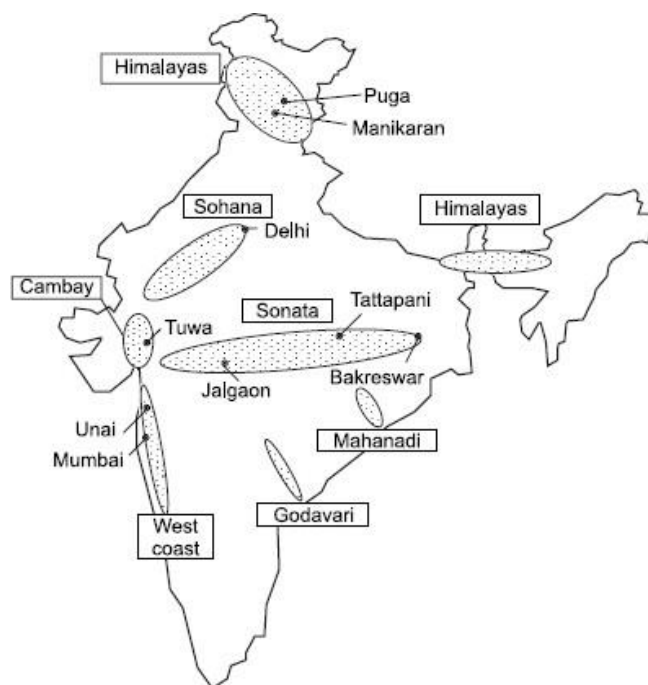

Figure Geothermal provinces of India (not to scale)

The geothermal reservoirs suitable for power generation have been located at Tattapani (in Sarguja district), Chhattisgarh and Puga valley of Ladakh, Jammu & Kashmir. Binary cycle system may be used for power generation from these medium enthalpy resources. A study by National Geophysical Research Institute (NGRI), Hyderabad has confirmed the presence of a 260 °C hydrothermal reservoir at a depth of 3 km at Tattapani. The Ministry of New and Renewable Energy Sources is planning to develop this field for power generation. Nation Hydroelectric Power Corporation (NHPC) has been entrusted the job of installing a 300 kW demonstration electric power production plant at a cost of Rs. 4.6 crore. Exploratory study is underway by NGRI, Hyderabad at Sutluj-Spiti, Beas and Parbati valley in Himachal Pradesh, Badrinath-Tapovan in Uttaranchal and Surajkund in Jharkhand to explore potential sites for power generation.

Geothermal fields in India [53, 54]

S.N.	Geothermal provinces	Main Locations	Estimated reservoir temp. (°C)	Heat flow (mW/m ²)	Thermal gradient (°C/km)
1.	Himalayas	Puga Valley (J&K), Manikaran (H.P.)	260	468	234
2.	Sohana		70		76-96
3.	West coast	Unai (Maharashtra)	102-137	129	59
4.	Cambay	Tuwa (Gujrat)	150-175	93	70
5.	Son-Narmada-Tapi (SONATA)	Jalgaon (Maharashtra), Tattapani (Chhattisgarh), Bakreswar (Bihar)	105-217	120-260	60-90
6.	Godavari		175-215	104	60
7.	Mahanadi		130	200	90

Since majority of these resources are located in rural India, these springs can support small-scale industries in such areas.

What are the Advantages of Using Geothermal?

1. Environmentally Friendly

Geothermal energy is more environmentally friendly than conventional fuel sources such as coal and other fossil fuels. In addition, the carbon footprint of a geothermal power plant is low. While there is some pollution associated with geothermal energy, this is relatively minimal when compared to fossil fuels.

2. Renewable

Geothermal energy is a source of renewable energy that will last until the Earth is destroyed by the sun in around 5 billion years. The hot reservoirs within the Earth

are naturally replenished, making it both renewable and sustainable.

3. Huge Potential

Worldwide energy consumption is currently around 15 terawatts, which is far from the total potential energy available from geothermal sources. While we can't currently use most reservoirs there is a hope that the number of exploitable geothermal resources will increase with ongoing research and development in the industry. It is currently estimated that geothermal power plants could provide between 0.0035 and 2 terawatts of power.

4. Sustainable / Stable

Geothermal provides a reliable source of energy as compared to other renewable resources such as wind and solar power. This is because the resource is always available to be tapped into, unlike with wind or solar energy.

5. Heating and Cooling

Effective use of geothermal for electricity generation requires water temperatures of over 150°C to drive turbines. Alternatively, the temperature difference between the surface and a ground source can be used. Due to the ground being more resistant to seasonal heat changes than the air, it can act as a heat sink/ source with a geothermal heat pump just two metres below the surface.

6. Reliable

Energy generated from this resource is easy to calculate since it does not fluctuate in the same way as other energy sources, such as solar and wind. This means we can predict the power output from a geothermal plant with a high degree of accuracy.

7. No Fuel Required

Since geothermal energy is a naturally occurring resource there is no fuel required, such as with fossil fuels that are a finite resource which needs mining or otherwise extracting from the earth.

8. Rapid Evolution

There is a great deal of exploration into geothermal energy at the moment, meaning that new technologies are being created to improve the energy process. There are an increasing number of projects to improve and grow this area of industry. With this rapid evolution many of the current cons of geothermal energy will be mitigated against.

What are the Disadvantages of Geothermal Energy?

1. Location Restricted

The largest single disadvantage of geothermal energy is that it is location specific. Geothermal plants need to be built in places where the energy is accessible, which means that some areas are not able to exploit this resource. Of course, this is not a problem if you live in a place where geothermal energy is readily accessible, such as Iceland.

2. Environmental Side Effects

Although geothermal energy does not typically release greenhouse gases, there are many of these gases stored under the Earth's surface which are released into the atmosphere during digging. While these gases are also released into the atmosphere naturally, the rate increases near geothermal plants. However, these gas emissions are still far lower than those associated with fossil fuels.

3. Earthquakes

Geothermal energy also runs the risk of triggering earthquakes. This is due to alterations in the Earth's structure as a result of digging. This problem is more prevalent with enhanced geothermal power plants, which force water into the Earth's crust to open up fissures to greater exploitation of the resource. However, since most geothermal plants are away from population centres, the implications of these earthquakes are relatively minor.

4. High Costs

Geothermal energy is an expensive resource to tap into, with price tags ranging from around \$2-\$7 million for a plant with a 1 megawatt capacity. However, where the upfront costs are high, the outlay can be recouped as part of a long-term investment.

5. Sustainability

In order to maintain the sustainability of geothermal energy fluid needs to be pumped back into the underground reservoirs faster than it is depleted. This means that geothermal energy needs to be properly managed to maintain its sustainability.

It is important for industry to assess the geothermal energy pros and cons in order to take account of the advantages while militating against any potential problems.

Module - 5

Introduction

Biomass and Biogas

The energy obtained from organic matter, derived from biological organisms (Plants and animals) is known as biomass energy. Animals feed on plants, and plants grow through the photosynthesis process using solar energy. Thus, photosynthesis process is primarily responsible for the generation of biomass energy. A small portion of the solar radiation is captured and stored in the plants during photosynthesis process. Therefore, it is an indirect form of solar into biomass energy is estimated to be 0.5 – 1.0%. To use biomass energy, the initial biomass may be transformed by chemical or biological processes to produce intermediate bio-fuels such as methane, producer gas, ethanol and charcoal etc. On combustion it reacts with oxygen to release heat, but the elements of the material remain available for recycling in natural ecological or agricultural processes. Thus, the use of industrial bio-fuels, when linked carefully to natural ecological cycle, may be non-polluting and sustainable. It is estimated that the biomass, which is 90% in trees, is equivalent to the proven current extractable fossil fuels reserves in the world. The dry matter mass of biological material cycling in biosphere is about 250×10^9 tons/y. The associated energy bound in photosynthesis is 2×10^{21} J/y (0.7×10^{14} W of power).

Biomass mainly in the form of wood, is mankind's oldest form of energy. It has traditionally been used both in domestic as well as industrial activities, basically by direct combustion. As industrial activities increased, the growing demand for energy depleted the biomass natural reserves. The development of new, more concentrated and more convenient sources of energy has led to its replacement to a large extent by other sources. Though biomass energy share in primary energy supply for the industrialized countries is not more than 3%, a number of developing countries still use a substantial amount of it, mostly in the form of non-commercial energy.

Main advantages of biomass energy are:

- i. It is a renewable source.
- ii. The energy storage is an in-built feature of it.
- iii. It is an indigenous source requiring little or no foreign exchange.
- iv. The pollutant emissions from combustion of biomass are usually lower than those from fossil fuels.
- v. Commercial use of biomass may avoid or reduce the problems of waste disposal in other industries, particularly municipal solid waste in urban centers.
- vi. The nitrogen rich bio-digested slurry and sludge from biogas plant serves as a very good soil conditioner and improves the fertility of the soil.

Main disadvantages are:

- i. It is a dispersed and land intensive source.
- ii. It is often of low energy density.

iii. It is also labour intensive, and the cost of collecting large quantities for commercial application is significant.

Most current commercial applications of biomass energy use material that has been collected for other reasons, such as timber and food processing residues and urban waste.

Biomass: It is the organic matter consisting of plant animal matter. Any matter which is biodegradable is known as biomass or organic matter. Generation of energy from biomass is referred to as _Photo chemical 'harnessing of solar radiation since to generate biomass; solar radiation is a must as seen from the following equation

Solar radiation \longrightarrow Photosynthesis \longrightarrow Biomass \longrightarrow Energy

Energy from the biomass is generated in three different forms namely) Direct burning, ii) Liquefaction, iii) Gas generation.

Direct burning: When biomass is directly burnt, energy is generated as given by the following expression,

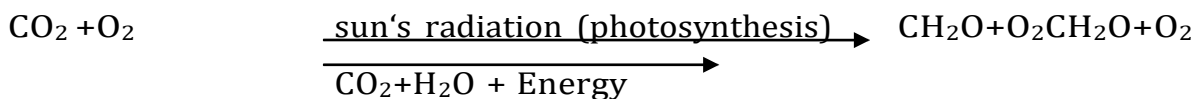

Thus when photosynthesis reaction is reversed energy is liberated.

Liquefaction: Biomass is liquefied either by thermo-chemical method or biochemical method to generate alcohols like methyl and ethyl alcohol. These are mixed with petrol and used in IC Engines as fuels.

Bio gas: Biomass is converted to biogas by the process of digestion or fermentation in the presence of micro-organisms. This biogas mainly contains methane which is a good combustible gas.

Biogas consists of 50-55% of methane, 30-35% of CO₂ and remaining waste gases like H₂, N₂, H₂S etc. since it contains a hydrocarbon gas it is a very good fuel and hence can be used in IC engines. It is a slow burning gas with calorific value of 5000-5500 Kcal/kg. the raw material used to generate this are algae, crop residue, garbage, kitchen waste, paper waste, waste from sugar cane refinery, water hyacinth etc. apart from the above- mentioned raw materials excreta of cattle, piggery waste and poultry droppings are also used as raw materials.

Biogas is generated by fermentation or digestion of organic matter in the presence of aerobic and anaerobic micro-organisms. Fermentation is the process of breaking down the complex organic structure of the biomass to simple structures by the action of micro-organisms either in the presence of O₂ or in the absence of O₂. The container in which the digestion takes place is known as the digester.

Advantages

- The initial investment is low for the construction of biogas plant.
- The technology is very suitable for rural areas.
- Biogas is locally generated and can be easily distributed for domestic use.
- Biogas reduces the rural poor from dependence on traditional fuel sources, which lead to deforestation.
- The use of biogas in village helps in improving the sanitary condition and checks environmental pollution.
- The by-products like nitrogen rich manure can be used with advantage.
- Biogas reduces the drudgery of women and lowers incidence of eye and lung diseases.

The digestion takes place in the following steps

i) Enzymatic hydrolysis ii) Acid formation iii) Methane formation.

i) **Enzymatic hydrolysis:** In this step the complex organic matter like starch, protein, fat, carbohydrates etc are broken down to simple structures using anaerobic micro-organisms.

ii) **Acid formation:** In this step the simple structures formed in the enzymatic hydrolysis step are further reacted by anaerobic and facultative micro-organisms (which thrive in both the presence and absence of oxygen) to generate acids.

iii) **Methane formation:** In this step the organic acids formed are further converted to methane and CO₂ by anaerobic micro-organisms (anaerobes).

Factors affecting Biogas generation:

- 1) PH value
 - 2) Temperature
 - 3) Total solid content
 - 4) Load rating
 - 5) Seeding
 - 6) Uniform feeding
 - 7) Dia to depth ratio
 - 8) Carbon to nitrogen ratio
 - 9) Nutrient
 - 10) Mixing
 - 11) Retention time
 - 12) Type of feedstock
-

- 13) Toxicity
- 14) Pressure

1) **PH value:** It is an index of hydrogen ion concentration in the mixture which also predicts acidity or alkalinity of the mixture. For effective gas generation the required PH value is 6.5 to 7.6. If this value decreases to 4-6, the mixture becomes acidic and if the value becomes 9-10 then it becomes alkaline. Both for acidic and alkaline conditions the methane forming bacteria becomes inactive and the gas generation is reduced. Thus for effective gas generation the required PH value is 6.5-7.5.

2) **Temperature:** The effect of temp on gas generation is as shown in graph. The two curves represent two types of bacteria which are sensitive to two different temp levels. Mesophilic type of bacteria will effectively generate gas at a temp of about 35° C. Thermophilic type of bacteria will generate gas effectively at a temp of about 55° C. As the temperature decreases or increases from the above values the period of gas generation will be increased. Since it is easy to maintain a temp of 35° C, it is advisable to select mesophilic type of bacteria for digestion.

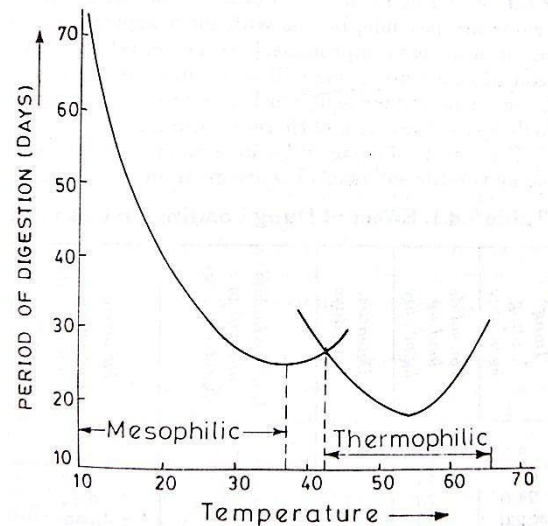

Fig. 7.5.1. Effect of temperature on digestion.

3) **Total solid content:** The raw material added to the digester contains both solid and liquid in the ratio of 20:80 by weight. From the experience it is found that the gas generation is improved by maintaining the solid content of the mixture at about 8 to 10% by weight. This is done by adding water to the mixture.

4) **Loading rate:** It is the addition of the raw material to the digester/day/unit volume. The effective load rating is found to be 0.5 to 1.6 kg of solid material/day/m³.

5) **Seeding:** During digestion the methane forming bacteria are consumed rapidly and their number will decrease affecting the gas generation. In order to maintain the quantity of methane forming bacteria, digested slurry from the previous batch is added to the digester. The digested slurry is rich in methane forming bacteria and the process is known as seeding.

6) **Uniform feeding:** this is one of the prerequisites of good digestion. The digester must be fed at the same time every day with a balanced feed of the same quality and

quantity.

- 7) **Dia to depth ratio:** from the experiments it is seen that the gas generation is improved by maintaining a dia to depth ratio of 0.66 to 1. This provides uniform temp distribution throughout the digester resulting in increased gas generation.
- 8) **Carbon to nitrogen ratio:** The bacteria in the digester utilize carbon for energy generation (as food) while nitrogen is used for cell building. Hence a carbon to nitrogen ratio of 30:1 is maintained for effective gas generation. If the ratio is not maintained the availability of carbon and nitrogen will vary resulting in reduced gas generation.
- 9) **Nutrients:** The nutrients required by the bacteria for food digestion are hydrogen, nitrogen, oxygen, carbon, phosphorous and Sulphur. Of these nitrogens and phosphorous have to be provided externally while the others are contained in the raw material itself. Nitrogen is provided by adding leguminous plants (plants with seeds enclosed in casings, eg: Maize) which are rich in nitrogen content. Phosphorous is provided by adding 'night soil' (soil mixed with excreta of animals and humans) to the digester.
- 10) **Mixing:** Since bacteria in the digester have very limited reach to their food it is necessary that the slurry is properly mixed and the bacteria get their food supply. It is found that the slight mixing improves the digestion and a violent mixing retards the digestion.
- 11) **Retention time:** It is the time period required for the gas generation. It completely depends on the type of the raw materials used. Eg: Night soil requires 30 days, pig dump and poultry droppings require 20 days while cow dung and other kitchen waste requires 50 days of retention time.
- 12) **Type of feed stock:** The usual feed stock used are cow dung, human excreta, poultry dropping, pig dump, kitchen waste etc. To obtain an efficient digestion these feed stocks are in some proportions, Predigested and finally chopping will be helpful for fibrous type of raw materials.
- 13) **Toxicity:** If the digester is left with the digested slurry it results in toxicity which in turn reduces the gas generation. Hence the digested slurry should be removed after the gas is generated.
- 14) **Pressure:** It is found that the gas generation is increased with the decrease in the pressure of the digester.

Photosynthesis Process:

Solar radiation incident on green plants and other photosynthetic organisms performs two basic functions: (i) temperature control for chemical reactions to proceed, and (ii) Photosynthesis process. The fundamental conversion process in green plants is photosynthesis, which is the process of combining CO₂ from the atmosphere with water plus light energy to produce oxygen and carbohydrates (sugars, starches, celluloses and hemicelluloses). They are the ultimate source of most of our foods and other necessities of daily life such as clothes (in the form of cotton), furniture (in the form of wood), etc.



The generalized symbol C_x (H₂O)_y is used to indicate the carbohydrates. The products of this reaction are about 5eV per C atom higher in energy than the initial material. Photosynthesis is a complex process. It involves several successive stages, but the overall basic Reaction is the formation of hexose (glucose, fructose, etc.) as represented by:

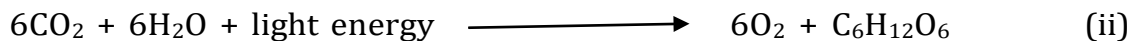

More complex hydrocarbons (sucrose, starch, cellulose, etc.) are formed by a chain of these simple structures. The reverse of this process is called respiration, in which CO₂, H₂O and energy are produced using carbohydrate and oxygen. In green plants, both photosynthesis and respiration occur during the day and only respiration at night. This is shown in figure below. There is a net overall gain of energy in the process, as the rate of energy loss in respiration is much less as compared to rate of energy gain during photosynthesis process. The process also results in net gain of oxygen and fixation of carbon in the form of biomass. The net energy absorbed from solar radiation during photosynthesis can be measured from its combustion.

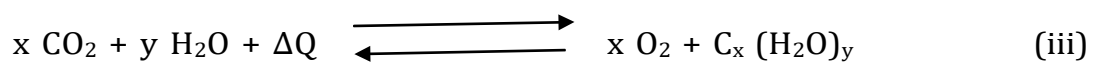

ΔQ is enthalpy change of the combustion process, equal to the energy absorbed from photons of solar radiation, less the energy of respiration during growth. The value of ΔQ is 4.8eV per carbon atom, 470kJ per mole of carbon or 16 MJ/kg of dry carbohydrate material. It is to be noted that the combustion requires the temperature of approximately 400^oC, whereas respiration occurs at 20^oC through catalytic enzyme reactions.

The uptake of CO₂ by a plant leaf is a function of many factors, especially temperature, CO₂ concentration and the intensity and wavelength distribution of light. Solar radiation incident on a leaf is reflected, transmitted and absorbed. Part of the absorbed radiation (<5%) provides the energy stored in the photosynthesis and produces oxygen and carbohydrate; the remainder is absorbed in the plant as sensible heat raising its temperature, or as latent heat for water evaporation. Absorption is usually most marked in the blue and red regions.

Biochemical reactions in anaerobic digestion:

There are four key biological and chemical stages of anaerobic digestion: Hydrolysis
Acido genesis Aceto genesis Methano genesis.

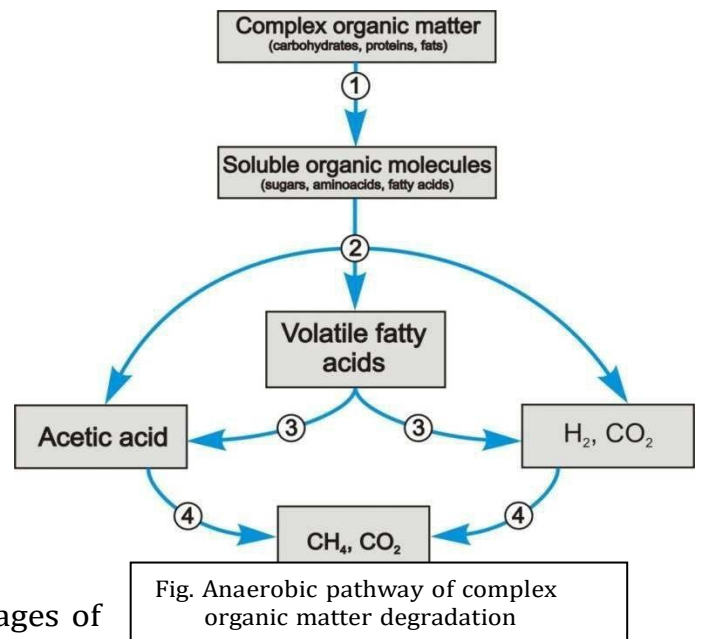

In most cases biomass is made up of large organic compounds. In order for the microorganisms in anaerobic digesters to access the chemical energy potential of the organic material, the organic matter macromolecular chains must first be broken down into their smaller constituent parts. These constituent parts or monomers such as sugars are readily available to microorganisms for further processing. The process of breaking these chains and dissolving the smaller molecules into solution is called hydrolysis. Therefore hydrolysis of high molecular weight molecules is the necessary first step in an aerobic digestion. It may be enhanced by mechanical, thermal or chemical pretreatment of the waste. Hydrolysis step can be merely biological (using hydrolytic microorganisms) or combined: bio-chemical (using extra cellular enzymes), chemical (using catalytic reactions) as well as physical (using thermal energy and pressure) in nature.

Acetates and hydrogen produced in the first stages can be used directly by methanogens. Other molecules such as volatile fatty acids (VFA's) with a chain length that is greater than acetate must first be catabolised into compounds that can be directly utilized by methanogens. The biological process of acidogenesis is where there is further break down of the remaining components by acidogenic (fermentative) bacteria. Here VFA's are generated along with ammonia, carbon dioxide and hydrogen sulphide as well as other by-products.

The third stage anaerobic digestion is acetogenesis. Here simple molecules created through the acidogenesis phase are further digested by acetogens to produce largely acetic acid (or its salts) as well as carbon dioxide and hydrogen.

The final stage of anaerobic digestion is the biological process of methanogenesis. Here

methanogenic archaea utilize the intermediate products of the preceding stages and convert the min to methane, carbon dioxide and water. It is these components that makes up the majority of the biogas released from the system. Methanogenesis is-beside other factors-sensitive to both high and low pH values and performs well between pH 6.5 and pH 8. The remaining, non-digestible organic and mineral material, which the microbes cannot feed upon, along with any dead bacterial residues constitutes the solid digestate.

Classification of the biogas plants:

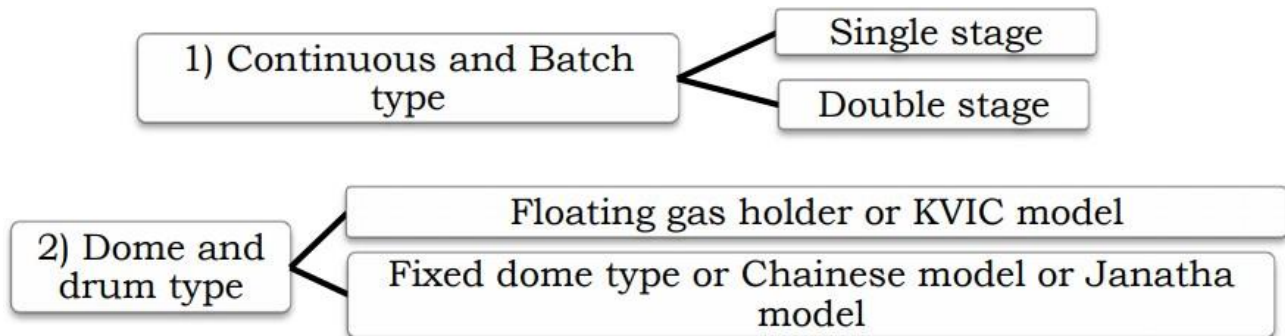

Variation in the above type

Single stage continuous plant:

The entire process of conversion of complex organic compounds into biogas is completed in a single chamber. This chamber is regularly fed with the raw materials while the spent residue keeps moving out. Serious problems are encountered with agricultural residues when fermented in a single stage continuous process.

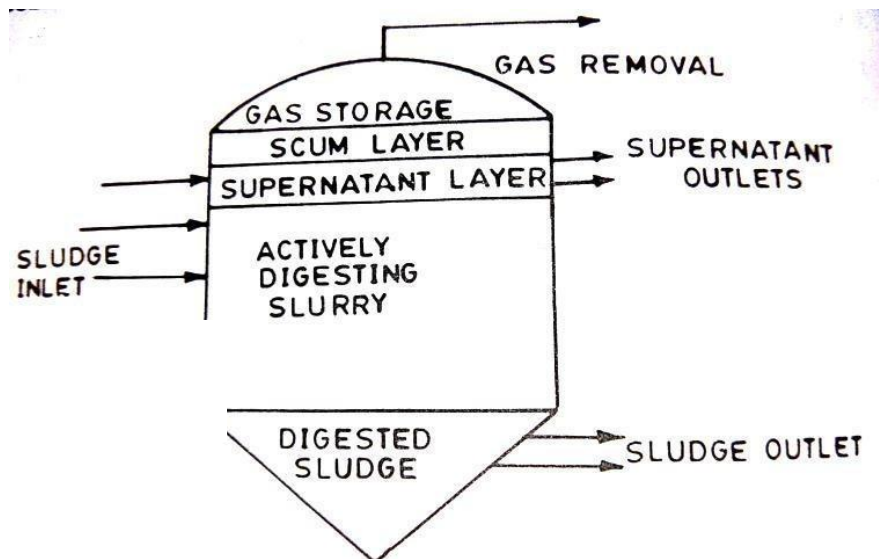
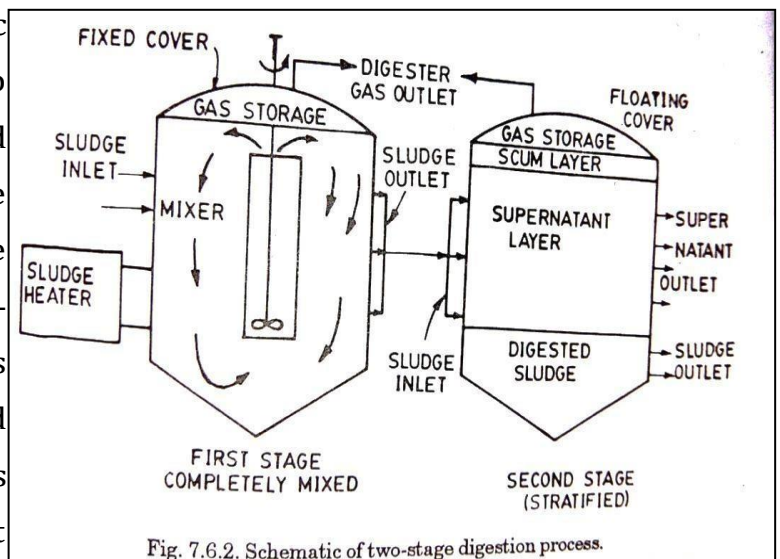

Fig. 7.6.1. Schematic of single process conventional digester.

Two stage continuous plant: (i) Acid & ii) Methane forming:

The acidogenic stage and methanogenic stage are physically separated into two chambers. Thus the first stage of acid production is carried out in a separate chamber and only the diluted acids are fed into the second chamber where bi-methanation takes place and the biogas can be collected from the second chamber. Considering the problems encountered in fermenting fibrous plant



waste materials the two-stage process may offer higher potential of success. However, appropriate technology suiting to rural India is needed to be developed based on the bauble stage process.

The main features of continuous plant are that:

- 1) It will produce gas continuously;
- 2) It requires small digestion chambers;
- 3) It needs lesser period for digestion;
- 4) It has fewer problems compared to batch type and it is easier in operation.

a) Indian Digester (Floating drum type/Khadi Vilege Industries Commission Plant (KVIC)):

This mainly consists of a digester or pit for fermentation and a floating drum for the collection of gas. Digester is 3.5-6.5 m in depth and 1.2 to 1.6 m in diameter. There is a partition wall in the center, which divides the digester vertically and submerges in the slurry when it is full. The digester is connected to the inlet and outlet by two pipes. Through the inlet, the dung is mixed with water (4:5) and loaded into the digester. The fermented material will flow out through outlet pipe. The outlet is generally connected to a compost pit. The gas generation takes place slowly and in two stages. In the first stage, the complex, organic substances contained in the waste are acted upon by a certain kind of bacteria, called acid formers and broken up into small-chain simpleacids. In

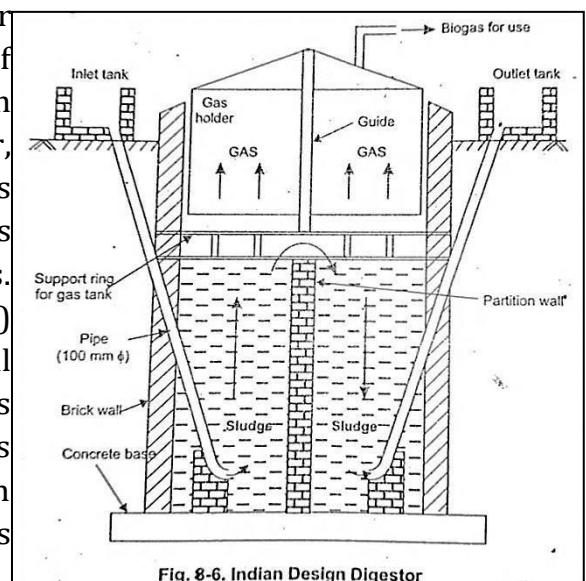

the second stage, these acids are acted upon by another kind of bacteria, called methane formers and produce methane and carbon dioxide.

Gas holder:

The gas holder is a drum constructed of mild steel sheets. This is cylindrical in shape with concave top. The top is supported radially with angular iron stripes. The holder fits into the digester like a stopper. It sinks into the slurry due to its own weight and rests upon the ring constructed for this purpose. When gas is generated the holder rises and floats freely on the surface of slurry. A central guide pipe is provided to prevent the holder from tilting. The holder also acts as a seal for the gas. The gas pressure varies between 7 and 9 cm of water column. Under shallow water table conditions, the adopted diameter of digester is more and depth is reduced. The cost of drum is about 40% of total cost of plant. It requires periodical maintenance. The unit cost of KVIC model with a capacity of 2 m³/day costs approximately Rs.14, 000/.

Janata type biogas plant (Chinese):

The design of this plant is of Chinese origin but it has been introduced under the name

—Janata biogas plant by Gobar Gas Research Station, Aajitmal in view of its reduced cost. This is a plant where no steel is used, there is no moving part in it and maintenance cost is low. The plant can be constructed by village mason taking some pre-explained precautions and using all the indigenously available building materials. Good quality of bricks and cement should be used to avoid the afterward structural problems like cracking of the dome and leakage of gas. This model have a higher capacity when compared with KVIC model, hence it can be used as a community biogas plant. This design has longer life than KVIC models. Substrates other than cattle dung such as municipal waste and plant residues can also be used in janata type plants. The plant consists of an underground well sort of digester made of bricks and cement having a domeshaped roof which remains below the ground level is shown in figure. At almost middle of the digester, there are two rectangular openings facing each other and coming up to a little above the ground level, act as an inlet and outlet of the plant. Dome shaped roof is fitted with a pipe at its top which is the gas outlet of the plant.

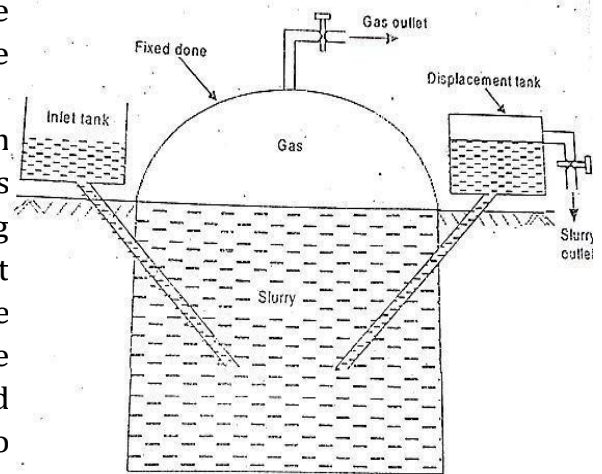
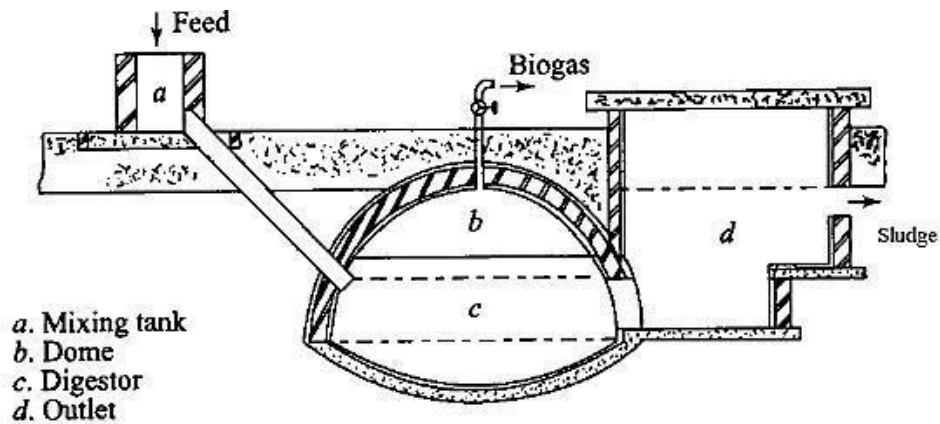

Fig. 8-7. Chinese design biogas plant

The principle of gas production is same as that of KVIC model. The biogas is collected in the restricted space of the fixed dome; hence the pressure of gas is much higher, which is around 90 cm of water column.

Deenbandhu biogas plant:



Deenbandhu model was developed in 1984, by Action for Food Production (AFPRO), a voluntary organization based in New Delhi. Schematic diagram of a Deenabandhu biogas plant entire biogas programme of India as it reduced the cost of the plant half of that of KVIC model and brought biogas technology within the reach of even the poorer sections of the population. The cost reduction has been achieved by minimizing the surface area through joining the segments of two spheres of different diameters at their bases. The cost of a Deenbandhu plant having a capacity of 2 m³/day is about Rs.8000/-. The Deenbandhu biogas plant has a hemispherical fixed- dome type of gas holder, unlike the floating dome of the KVIC-design is shown. The dome is made from pre-fabricated Ferro cement or reinforced concrete and attached to the digester, which has a curved bottom. The slurry is fed from a mixing tank through an inlet pipe connected to the digester. After fermentation, the biogas collects in the space under the dome. It is taken out for use through a pipe connected to the top of the dome, while the sludge, which is a by-product, comes out through an opening in the side of the digester. About 90% of the biogas plants in India are of the Deenbandhu type.

Problems Related to Bio-gas Plants:

Some problems are natural and some are created by the persons biogas plants owners but all are controllable.

1. Handling of effluent slurry is major problem if the person is not having sufficient open space or compost pits to get the slurry dry. Use of press filters and transportation is expensive and out of reach of poor farmers. For a domestic plant, 200 litres capacity oil drums can be used to carry this effluent to the fields but this will require some human-animal labour or consumption of diesel if a auto vehicle is used.

2. The gas forming-methanogenic bacteria are very sensitive towards the temperature compared to those of non-methanogenic. During winter as the temperature falls, there is decrease in the activity of methanogenic bacteria and subsequently fall in gas production rate. Many methods have been suggested to overcome this temperature problem as described earlier, e.g.,

- a) Use of solar heated hot water to make a slurry of influent but the temperature of water should not exceed 60°C otherwise the mesophilic bacteria will die.
- b) Circulation of hot water obtained either from solar heater or I.C. engine heat exchanger, through pipes inside the digester.
- c) Greenhouse effect also give good results but it is costlier and after few years the polythene sheet used in it becomes opaque.
- d) Addition of various nutrients for bacteria.
- e) Converting the biogas plant by straw bags during night hours.

3. Due to lack of proper training to the bio-gas plant owners for the operation of plant, a lot of problems arises. It has been noticed that many persons increase the loading rate and some also do not try to mix the cattle dung with water, keeping in mind more gas production. Due to this, the flow of slurry from inlet towards outlet is very slow or even stops. This may cause accumulation of volatile fatty acids and drop in Ph and then failure of digester. Also it is not possible to stir the digester content of high solid concentration.

4. Some persons add urea-fertilizer in large quantities due to which toxicity of ammonia nitrogen may cause a decrease in gas production.

5. pH and volatile fatty acids play an important role in anaerobic digestion and should remain under optimum range otherwise this may cause upsetting of digester and even its failure. pH can be checked from time to time by the use of cheap and easily available pH paper but volatile fatty acids can only be determined in a laboratory having its testing facilities. For controlling pH in optimum range, it tends to fall below 7.0, lime has been suggested, as it is easily available cheap material and does not harm the activity of bacteria.

6. Leakage of gas from gas holder especially in case of Janta type biogas plants is a major and very common problem. When there is quite enough gas in a gas holder, the leakage should be checked by using water and the points marked and then get repaired. During repairing there should be no gas inside the gas holder

the stop cock remains open till repaired points get dry. Quality of constructing material such as cement is important.

Advantages of Biogas:

1. Biogas is an energy carrier which can be used for several energy applications (eg. electricity generation, heat production, combine heat and power production, transport fuel, injection to the natural gas grid).
2. Biogas can contribute to several sectors:
 - i) Environment
(eg. Fight against Climate change)
 - ii) Energy
(eg. Energy security, local source)
 - iii) Agriculture
(eg. Sustainable cultivation and animal breeding)
 - iv) Society
(eg. Employment enhancement, rural development)
3. Some Environmental benefits of biogas:
 - i) Reduced emissions of greenhouse gases, direct and indirect (eg. CO₂, CH₄ and nitrous oxide –N₂O).
 - ii) Water and Waste management (Reduced consumption of resources and increased recycling, reduced water environment pollution from leaching of nutrients, environmental friendly solution to the waste disposal problem).
 - iii) Reduced odour and flies nuisances.
 - iv) Soil and landscape
4. Emissions reduction of greenhouse gases (eg. CO₂, CH₄ and nitrous oxide –N₂O).

Direct: The combustion of biogas also releases CO₂. Compared to fossil fuels, the carbon in biogas was recently up taken from the atmosphere, by photosynthetic activity of the plants (closed carbon cycle) .

- Biogas production by AD reduces also emissions of methane (CH₄) and nitrous oxide (N₂O) from storage and utilization of animal manure as fertilizer. It is worth mentioning that although biogas is a potential low carbon energy source, this depends on the way biogas is produced. In the case that biogas comes from residues, waste or from energy crops grown on abandoned agricultural and this offers sustained GHG advantages.

- Emissions reduction of greenhouse gases (eg. CO₂, CH₄ and nitrous oxide –N₂O).

Indirect:

- Utilization of biogas substitute fossil fuel (such as lignite, hard coal, crude oil and natural gas) and thus reduces emissions (externalities).

5. Water and Waste management

- Compared to other biofuels, biogas needs the lowest amount of process water. This aspect is very important since many regions of the world face huge water problems

- One of the main advantages of biogas production is the ability to transform waste material into a valuable resource, by using it as feedstock for AD.
- Biogas technologies contribute to reduce the volume of wastes and the costs for waste disposal (transportation, disposal).

6. Health issues, odor and flies utilization of digestate as fertilizer improves veterinary safety, when compared to untreated manure and slurries.

AD reduces odours (positive change in the composition of odours as well). Digestate is almost odourless and the remaining disappear shortly after application as fertilizer on the fields (ammonia odours).

7. Employment
8. Rural development
9. Local economy and Energy Market development

Application of bio-gas in engines:

Biogas in Diesel Engine applications:

Biogas generally has a high self-ignition temperature hence; it cannot be directly used in a CI engine. So it is useful in dual fuel engines. The dual fuel engine is a modified diesel engine in which usually a gaseous fuel called the primary fuel is inducted with air into the engine cylinder. This fuel and air mixture does not auto ignite due to high octane number. A small amount of diesel, usually called pilot fuel is injected for promoting combustion. The primary fuel in dual fuelling system is homogeneously mixed with air that leads to very low level of smoke. Dual fuel engine can use a wide variety of primary and pilot fuels. The pilot fuels are generally of high cetane fuel. Biogas can also be used in dual fuel mode with vegetable oils as pilot fuels in diesel engines. Introduction of biogas normally leads to deterioration in performance and emission characteristics. The performance of engine depends on the amount of biogas and the pilot fuel used. Measures like addition of hydrogen, LPG, removal of CO₂ etc. Have shown significant improvements in the performance of biogas dual fuel engines. The ignition delay of the pilot fuel generally increases with the introduction of biogas and this will lead to advance the injection timing. Injectors opening pressure and rate of injection also are found to play important role in the case of biogas fuelled engine, where vegetable oil is used as a pilot fuel. The CO₂ percentage in biogas acts as diluents to slow down the combustion process in Homogenous charged compression ignition (HCCI) engines. However, it also affects ignition. Thus a fuel with low self-ignition temperature could be used along with biogas to help its ignition. This kind of engine has shown a superior performance as compared to a dual fuel mode of operation.

Biogas in Dual Fuel Engine applications:

In this case, the normal diesel fuel injection system still supplies a certain amount of diesel fuel. The engine however sucks and compresses a mixture of air and biogas fuel which has been prepared in external mixing device. The mixture is then ignited by and together with the diesel fuel sprayed in. The amount of diesel fuel needed for sufficient ignition is between 10% and 20% of the amount needed for operation on diesel fuel alone. Operation of the engine at partial load requires reduction of the biogas supply by means of a gas *control* valve. A simultaneous reduction of airflow would reduce power and efficiency because of reduction of compression pressure and main effective pressure. So, the air/fuel ratio is changed by different amounts of injected

biogas. All other parameters and elements of diesel engine remain unchanged.

Biogas As Alternate Fuel In Diesel Engines: A Literature Review Modification of diesel engine into dual fuel engine Advantages-Operation on diesel fuel alone is possible when biogas is not available.-Any contribution of biogas from 0% to 85% can substitute a corresponding part of diesel fuel while performance remains as in 100% diesel fuel operation.-Because of existence of a governor at most diesel engines automatic control of speed/power can be done by changing the amount of diesel fuel injection while the biogas flow remains uncontrolled. Diesel fuel substitutions by biogas are less substantial in this case.

Limitations:

- The dual fuel engine cannot operate without the supply of diesel fuel for ignition.
- The fuel injection jets may overheat when the diesel fuel flow is reduced to 10% or 15% of its normal flow. Larger dual fuel engines circulate extra diesel fuel through the injector for cooling.
- To what extent the fuel injection nozzle can be affected is however a question of its specific design, material and the thermal load of the engine, and hence differs from case to case.
- A check of the injector nozzle after 500 hours of operation in dual fuel is recommended.

Biogas in HCCI Engine applications:

The Homogeneous Charge Compression Ignition (HCCI) concept is a potential for achieving a high thermal efficiency and low Nitrogen Oxide (NO) emission. The HCCI engine with 50 % biogas as a primary fuel and 50% diesel as pilot fuel gives a maximum NO of 20 ppm is a major advantage over biogas diesel dual fuel mode. In biogas diesel dual fuel mode, the presence of CO₂ in biogas lowers the thermal efficiency however, in biogas diesel HCCI (BDHCCI) mode CO₂ reduces high heat release rate. The breakmean effective pressure (BMEP) in BDHCCI mode is in the range of 2.5 bar to 4 bar. The smoke and Hydro Carbon (HC) level were also low when the biogas is used as a primary fuel for BDHCCI mode. For HCCI operation the inducted charge temperature is required to be maintained at 80-135°C, which can be obtained from the exhaust heat. Thus, biogas with HCCI engine gives high efficiency and low emission.

Hydrogen energy:

Hydrogen is the simplest element. An atom of hydrogen consists of only one proton and one electron. It is also the most plentiful element in the universe. Despite its simplicity and abundance, hydrogen doesn't occur naturally as a gas on the Earth – it is always combined with other elements. Water, for example, is a combination of hydrogen and oxygen (H₂O).

Hydrogen holds the potential to provide clean, reliable and affordable energy supply that can enhance economy, environment and security. It is flexible and can be used by all sectors of economy.

Hydrogen can be produced by using a variety of energy sources, such as solar, nuclear and fossil fuels and can be converted to useful energy forms efficiently and without detrimental environmental effects. When burned as fuel or converted to electricity it joins with oxygen to produce energy with water as the only emission. When air is used for combustion instead of oxygen, some NO_x is also produced, which can be reduced by lowering the combustion temperature.

Properties of Hydrogen

Hydrogen is an odorless and colorless gas. It has the simplest and lightest atom with one proton and one electron and molecular weight of 2.016. Important properties are listed and compared with natural gas and gasoline in Table.

SN	Properties	Gasoline	Natural gas	Hydrogen
1	Density (kg/m ³)	730	0.78	0.0837
2	Boiling point, (°C)	38 to 204	-156	-253 (20.3 K)
3	Lower heating value, (MJ/kg) (MJ/m ³)	44.5 32	48 37.3	125 10.4 (gas), 8520 (liquid)
4	Higher heating value, (MJ/kg) (MJ/m ³)	50.8 36.6	55 42.6	141.90 11.89 (gas), 10046 (liquid)
5	Flammable limit, % in air	1.4–7.6	5–16	4–75
6	Flame speed, (m/s)	0.4	0.41	3.45
7	Flame temperature, (°C)	2197	1875	2045
8	Flame luminosity	High	Medium	Low

Production:

Although hydrogen is the third most abundant element on the earth, it does not exist in Free State, except for small quantities in the upper atmosphere. It is, therefore, not a primary energy source. It can therefore, be produced through two routes:

- a) Fossil fuels, such as natural gas, coal, methanol, gasoline etc., and biomass are decomposed by thermo-chemical (steam reforming or partial oxidation) methods to obtain hydrogen. The CO produced in the process is eliminated by water gas shift reaction. This route of hydrogen production causes CO₂ emission. The energy

content of the produced hydrogen is less than the energy content of the original fuel, some of it being lost as excessive heat during production.

- b) Hydrogen can also be produced by splitting water into hydrogen and oxygen by using energy from nuclear or renewable sources such as solar, wind, geothermal, etc., through electrical or thermal means (i.e. electrolysis and thermolysis respectively). Water splitting is also possible through biophotolysis process using solar radiation.

1. Electrolysis of Water:

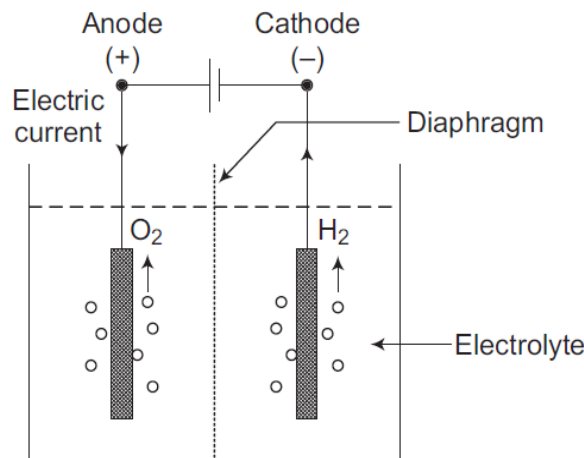

Fig: Electrolytic cell

Electrolysis is the simplest method of hydrogen production. Currently, this method is not as efficient or cost effective as thermo-chemical method using fossil fuels or biomass. But it would allow for more distributed hydrogen generation and open the possibilities for use of electricity generated from renewable and nuclear resources for hydrogen production.

An electrolysis cell essentially consists of two electrodes, commonly flat metal or carbon plates, immersed in an aqueous conducting solution called electrolyte, as shown in Fig. A direct current decomposes water into H₂ and O₂, which are released at cathode (-ve electrode) and anode (+ve electrode) respectively. As water itself is poor conductor of electricity, an electrolyte, commonly aqueous KOH is used.

Ideally, a decomposition voltage of 1.23 V per cell should be sufficient at normal temperature and pressure; however, due to various reasons a voltage of about 2 V per cell is applied in practice. The energy required is 3.9–4.6 kWh per m³ of hydrogen produced. About 60–70 per cent of this energy is actually utilized in electrolysis.

Therefore, the efficiency of electrolysis process is about 60–70 per cent, which can be improved up to 80 per cent by using catalyst such as porous platinum or nickel. A diaphragm (usually woven asbestos) prevents electronic contact between the electrodes and passage of gas or gas bubbles. Electrolysis method is most suitable when primary energy is available as electrical energy, e.g. solar photovoltaic energy. It is also suitable where cheap electricity is available from other sources such as wind, geothermal, etc.

Thermal Decomposition of Water (thermolysis of water):

When primary energy is available in the form of heat (e.g. solar thermal), it is more logical to produce hydrogen by splitting water directly from heat energy using thermolysis. This would be more efficient than conversion of heat, first to electricity (using heat engine generator) and then producing hydrogen through electrolysis. The efficiency of thermal plant is usually in range 32–38 per cent and that of electrolysis is 80 per cent. The overall efficiency through thermal-electrical-hydrogen route would thus be only 25–30 per cent.

Direct thermal decomposition of water is possible but it requires a temperature of at least 2500 °C; because of temperature limitations of conversion process equipment, direct single-step water decomposition cannot be achieved. However, sequential chemical reactions at substantially lower temperature can be devised to split water into H₂ and O₂. In the reaction series, water is taken up at one stage and H₂ and O₂ are produced in different stages. The energy is supplied as heat at one or more stages and partly released at some stage in the cycle.

Apart from decomposition of water, all other materials are recovered when the cycle is completed. Therefore, the method is known as thermo-chemical cycle. The efficiency of conversion from heat energy to hydrogen is better than its conversion through electrolysis route only when the upper temperature of thermo-chemical cycle is above 700 °C. For the upper temperature of 950 °C the efficiency of conversion is about 50 per cent. This is a marked improvement over what is possible through electrolysis route. Several thermo-chemical cycles have been proposed and are under investigation. One such cycle is given below:

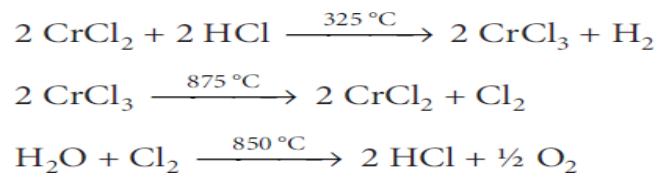

At present, no commercial process for thermal splitting of water using thermo chemical cycle is in operation.

Bio photolysis:

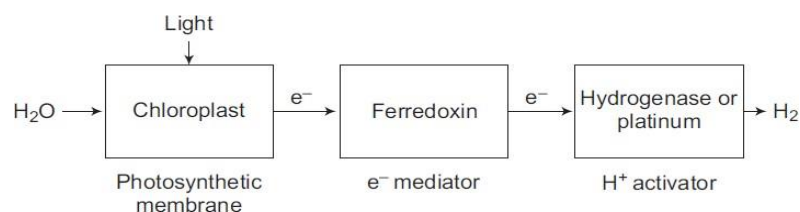

Fig: Functional components of bio photolysis

In this method the ability of the plants (especially algae) to split water during photosynthesis process is utilized. An artificial system is devised, which could produce hydrogen and oxygen from water in sunlight using isolated photosynthetic membrane

and other catalysts. Since this process is essentially a decomposition of water using photons in the presence of biological catalysts, the reaction is called photolysis of water. There are three distinct functional components coupled together in the system as shown in Fig.

- (i) Photosynthetic membrane, which absorbs light, split water to generate oxygen, electrons and protons,
- (ii) An electron mediator, which is reducible by photo-synthetically generated electrons and
- (iii) a proton activator that will accept electrons from the reduced mediator and catalyze the reaction:



A system with chloroplast (small bodies containing the chlorophyll in green plants) as a photosynthetic membrane to split hydrogen and oxygen, ferredoxin as e⁻ mediator and hydrogen as (an enzyme) or finely dispersed platinum as proton activator, has been successfully tested. The method is being extensively studied further.

Thermochemical Production:

Hydrogen bound in organic matter and in water makes up 70% of the earth's surface. Breaking up these bonds in water allows us produce hydrogen, and then, to use it as a fuel. There are numerous processes that can be used to break these bonds.

1. Steam Reforming:

Steam reforming uses thermal energy to separate hydrogen from the carbon components in methane and methanol and involves the reaction of these fuels with steam on catalytic surfaces. The first step of the reaction decomposes the fuel into hydrogen and carbon monoxide. Then, a 'shift reaction' changes the carbon monoxide and water to carbon dioxide and hydrogen. These reactions occur at temperatures of 200°C or greater.

Steam reforming of natural gas is currently the least expensive method and is responsible for more than 90% of hydrogen production worldwide. Natural gas is first cleared from sulphur compounds. It is then mixed with steam and send over a nickel-alumina catalyst inside a tubular reactor heated externally, where carbon monoxide (CO) and hydrogen (H₂) are generated. This step is followed by a catalytic water-gas shift reaction that converts the CO and water to hydrogen and carbon dioxide (CO₂). The hydrogen gas is then purified.

The endothermic reforming reaction is,

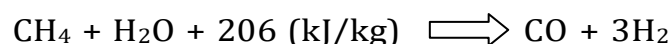

It is usually followed by the exothermic shift reaction:

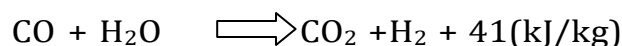

The overall reaction is:

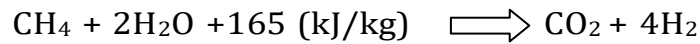

2. *Partial Oxidation or Ceramic Membrane Reactor:*

In the partial oxidation process, natural gas (or other liquid or gaseous hydrocarbons) and oxygen are injected into a high-pressure reactor. The oxygen to carbon ratio is optimally set for maximizing the yield of CO and H₂ and avoiding the formation of soot. Further steps and equipment remove the large amount of heat generated by the oxidation reaction, shift the CO with water to CO₂ and H₂, and remove the CO₂, which can then be captured, and purify the hydrogen produced. This process needs oxygen, which is usually provided by an air distillation plant.

Partial oxidation can also be helped by an oxidation catalyst. It is then called catalytic partial oxidation.

The partial oxidation reaction for natural gas is:

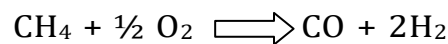

3. *Biomass Gasification and Pyrolysis:*

The thermal processing techniques for plant material (biomass) and fossil fuels are similar, with a number of the downstream unit operations being essentially the same for both feedstocks. Using agricultural residues and wastes, or biomass specifically grown for energy uses, hydrogen can be produced via pyrolysis or gasification. Biomass pyrolysis produces a liquid product (bio-oil) that, like petroleum, contains a wide spectrum of components that can be separated into valuable chemicals and fuels.

Unlike petroleum, bio-oil contains a significant number of highly reactive oxygenated components derived mainly from constitutive carbohydrates and lignin. These components can be transformed into products, including hydrogen. Co-product strategies are designed to produce high value chemicals, like phenolic resins, in conjunction with hydrogen.